

INSTRUCTIONS FOR INSTALLATION, USE AND MAINTENANCE



ED. 01-08

GB



MANTEGEL 20 - 30 - 50 - 70

- Condenser "Water"**
- Condenser "Air"**
- Condenser "Air/Water"**
- Dispositivo "Granita"**



MACCHINE E IMPIANTI
PER GELATO

ICE CREAM EQUIPMENTS
AND MACHINES

Sede (factory): Via Boschetti, 51 - 24050 Grassobbio (BG) **ITALY**
Tel.: ++39 035 4522062 Fax: ++39 035 4522682

Website: www.technogel.com
E-mail: info@technogel.com

EDITION 01-08 – This manual is the exclusive property of **TECHNOGEL spa**.
Any unauthorized reproduction of part or whole of this document is prohibited

Introduction

Thank you for choosing our product. For best results, we recommend that you read this instruction manual carefully.

The descriptions and illustrations contained in this manual are not binding. **TECHNOGEL** reserves the right to modify and improve, without notice and at any point, machine parts where deemed necessary for construction and/or commercial motives.

⇒ Persons qualified to carry out the work depending on the type of work involved

Please note the symbols given at the side of each operation described for installation, use and maintenance:



= Technician



= User

Where the symbol of the Technician is indicated (an electrician, plumber or mechanic) this means that the operations described can be carried out exclusively by these people. If the user attempts to carry out these operations this could prove dangerous and he/she must refrain from doing so.

⇒ Installation and first start-up



The installation and first startup of this machine must be carried out by a **TECHNOGEL** technician or one with **TECHNOGEL** authorization.

TECHNOGEL spa DECLINES ALL LIABILITY FOR INSTALLATIONS OR STARTUPS CARRIED OUT BY UNAUTHORIZED PERSONS.



How to unpack the machine

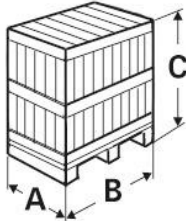

	GROSS WEIGHT	A	B	C
MANTEGEL 20 =	KG. 280	mm. 730	1030	1730
MANTEGEL 30 =	KG. 310	mm. 730	1030	1730
MANTEGEL 50 =	KG. 355	mm. 730	1100	1730
MANTEGEL 70 =	KG. 525	mm. 730	1320	1730

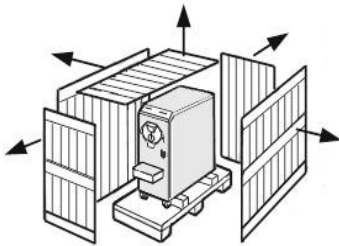

ATTENTION : DUE TO ITS NARROW AND HIGH SHAPE, THE MACHINE MAY BE UNSTABLE DURING HOISTING.

Remove all the side and top wooden panels

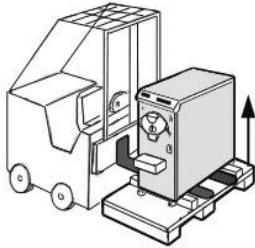

Lift the machine using a fork lift truck, inserting the forks between the machine base and the crate base

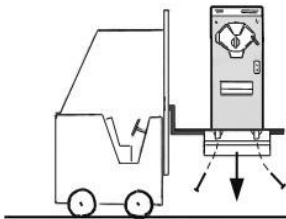

Under the crate base unscrew the four bolts that hold the machine tightly in position

ATTENTION:

After removing these bolts, the base of the crate will drop to the ground.

After removing the crate base, lower the fork lift truck and place the machine on the ground.

The machine can now be moved by means of the handles.

**THE TYPE OF WOOD USED FOR THE PACKING CRATE IS NATURAL SPRUCE,
NOT CHEMICALLY TREATED SO THAT IT CAN BE PERFECTLY RECYCLED.**



Hoisting the machine

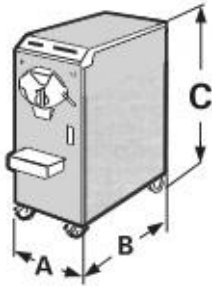

	NET WEIGHT	A	B	C
MANTEGEL 20 =	KG. 190	mm.490	620	1305
MANTEGEL 30 =	KG. 220	mm.490	600	1330
MANTEGEL 50 =	KG. 260	mm.490	740	1330
MANTEGEL 70 =	KG. 435	mm.490	940	1400

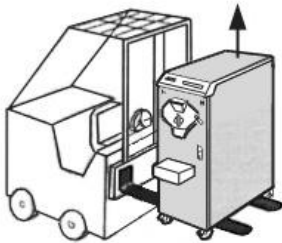

ATTENTION: DUE TO ITS NARROW AND HIGH SHAPE, THE MACHINE MAY BE UNSTABLE DURING HOISTING.

Lift the machine using a fork lift truck, inserting the forks from the side, between the front and rear wheels.



Hoist the machine with belts near the front and rear wheels (as in drawing).

The tie rod lifting the machine must be at the exact centre of the machine.

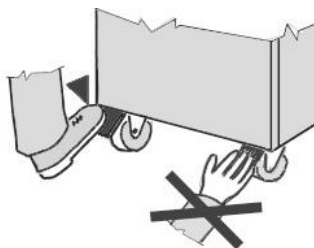

Move the machine by holding the flange handle in one hand and the corner of the machine in the other.

After positioning the machine, use your feet to lock with the front wheel brakes.

NEVER USE YOUR HANDS

Machine identification

Every machine is given a plate bearing:

- ⇒ machine type
- ⇒ electrical power
- ⇒ serial number
- ⇒ gas type and quantity
- ⇒ voltage and hertz ratings

This plate is found at the back of the machine. Below is the serial plate for this machine.

technogel

MACCHINA TIPO MACHINE TYPE	
MATRICOLA N. SERIAL NUMBER	N.
ANNO YEAR	
VOLTAGGIO VOLTAGE	V A
POTENZA POWER	KW
GAS FREON	R Kg

Via Boschetti 51, GRASSOBBIO
(BG) ITALIA
Tel. 035-4522062 Fax 035-4522682

CE

When ordering spare parts and requesting technical assistance, always quote the information given on the serial plate:

MACHINE TYPE	MANTEGEL
SERIAL NUMBER	
VOLTAGE	VOLT HZ

POSITIONEMENT MACHINE CONDENSER FOR WATER

CONNECTION WATER END ELECTRICAL

technician qualificate:

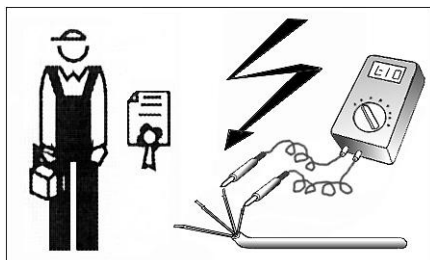

ELECTRICIAN

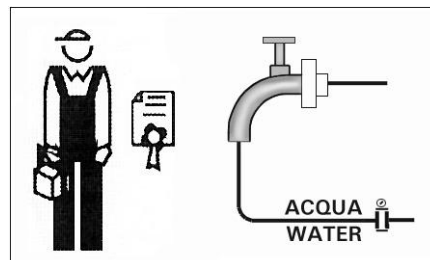

PLUMBER



Dimensions and different facilities: MANTEGEL 20

Dimensions and weight:

A – width	B – depth	C	H – height	Weight
19" 3/8	24" 7/16	7" 7/8	51" 3/8	419 Lb.
490 mm.	620 mm.	200 mm.	1305 mm.	190 Kg.

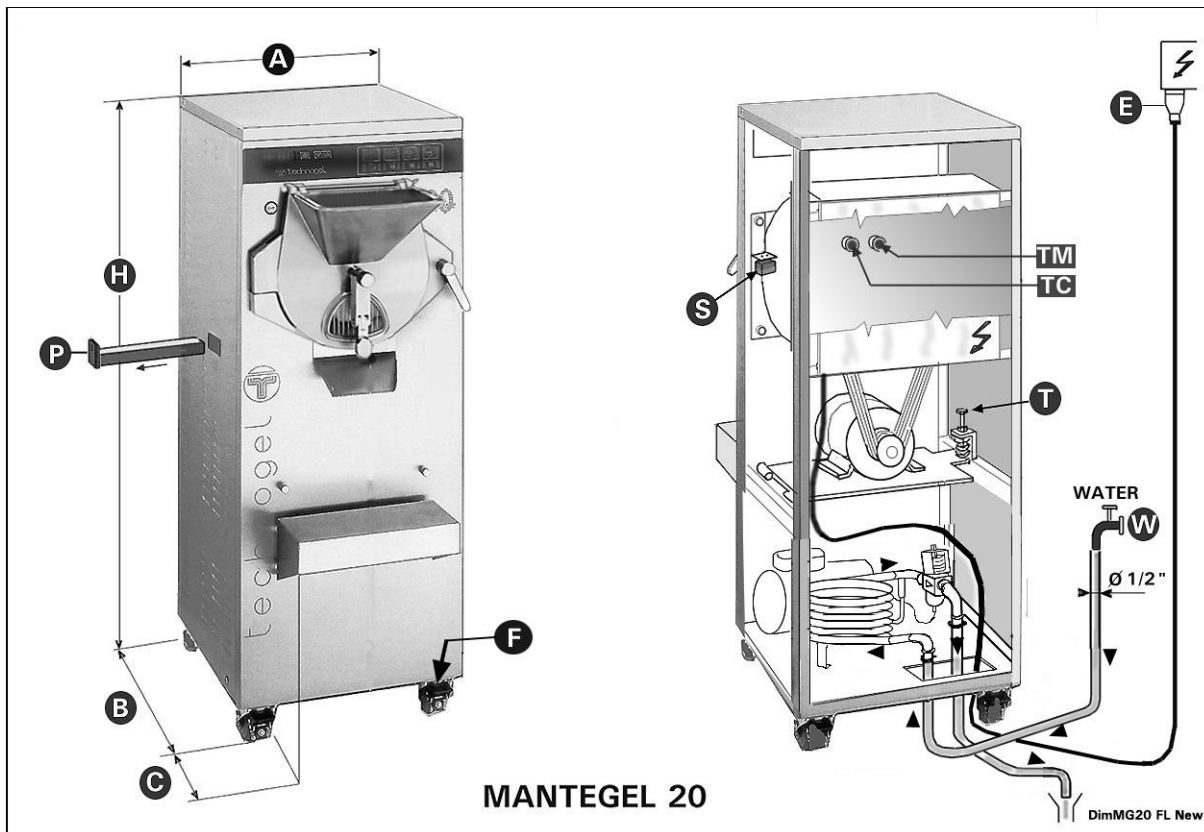

WARNING:

For the good functioning, the machine does not have to be anchored to the floor, neither some particular technical precaution are to be taken to limit the vibration transmission.

The installation requires the following operations:

- ⇒ Around the machine perimeter, leave an operative space of at least 10" (25 cm) necessary to carry out the works smoothly.
- ⇒ Make sure the machine is steady by blocking the brakes (F) of the front wheels using the feet (**DO NOT USE THE HANDS**).
- ⇒ Connect the hidro-system with the water inlet and outlet (see above picture point W). For the pressure and consumption data refer to page 12 (**MANTEGEL 20**).
- ⇒ Connect the electric system (see above picture point E). For the power and absorption data refer to page 10 (Table A - **MANTEGEL 20**).



Dimensions and different facilities: MANTEGEL 30

Dimensions and weight:

A – width	B – depth	C	H – height	Weight
19" 3/8	24" 7/16	7" 7/8	52" 3/8	485 Lb.
490 mm.	620 mm.	200 mm.	1330 mm.	220 Kg.

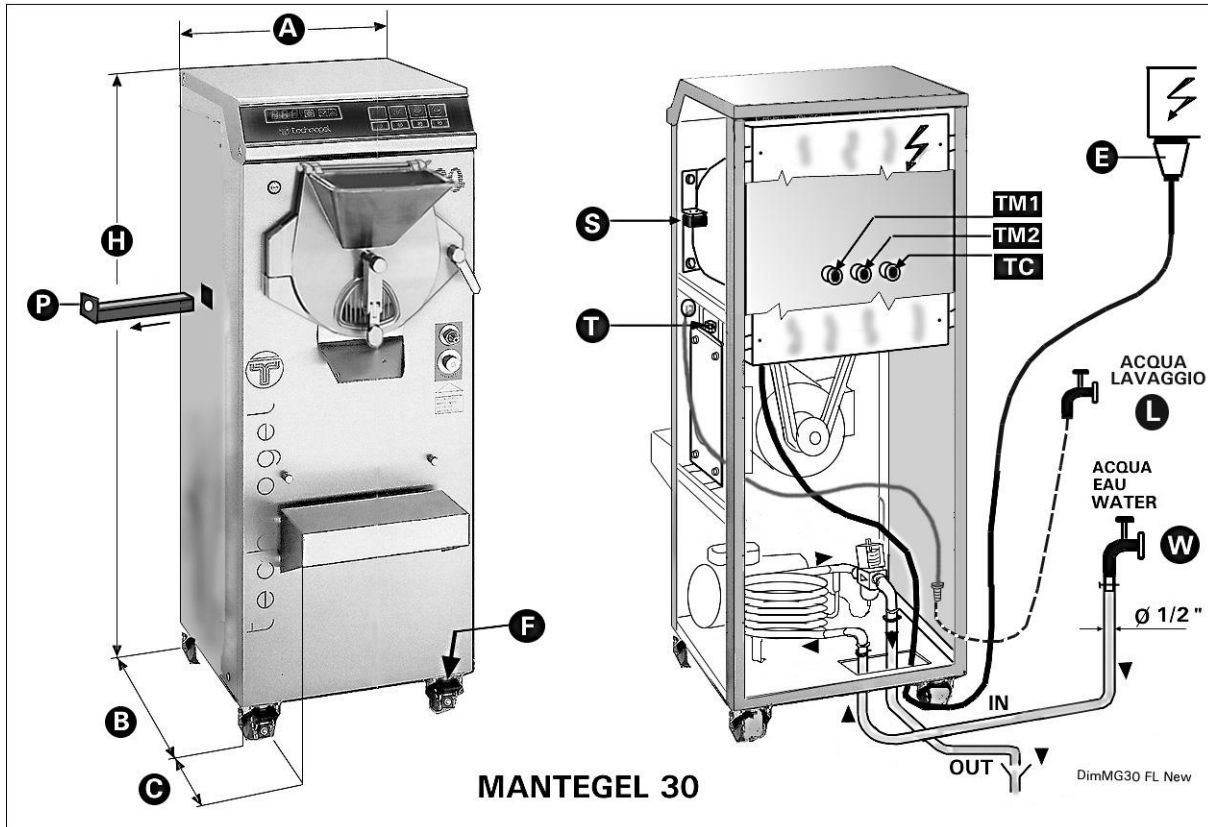

WARNING:

For the good functioning, the machine does not have to be anchored to the floor, neither some particular technical precaution are to be taken to limit the vibration transmission.

The installation requires the following operations:

- ⇒ Around the machine perimeter, leave an operative space of at least 10" (25 cm) necessary to carry out the works smoothly.
- ⇒ Make sure the machine is steady by blocking the brakes (F) of the front wheels using the feet (**DO NOT USE THE HANDS**).
- ⇒ Connect the hidro-system with the water inlet and outlet (see above picture point W). For the pressure and consumption data refer to page 12 (**MANTEGEL 30**). Connect, also, the washing water (L) cold or hot according to the availability.
- ⇒ Connect the electric system (see above picture point E). For the power and absorption data refer to page 10 (Table A - **MANTEGEL 30**).



Dimensions and different facilities: MANTEGEL 50

Dimensions and weight:

A – width	B – depth	C	H – height	Weight
19" 3/8	29" 1/2	7" 7/8	52" 3/8	640 Lb.
490 mm.	750 mm.	200 mm.	1330 mm.	290 Kg.

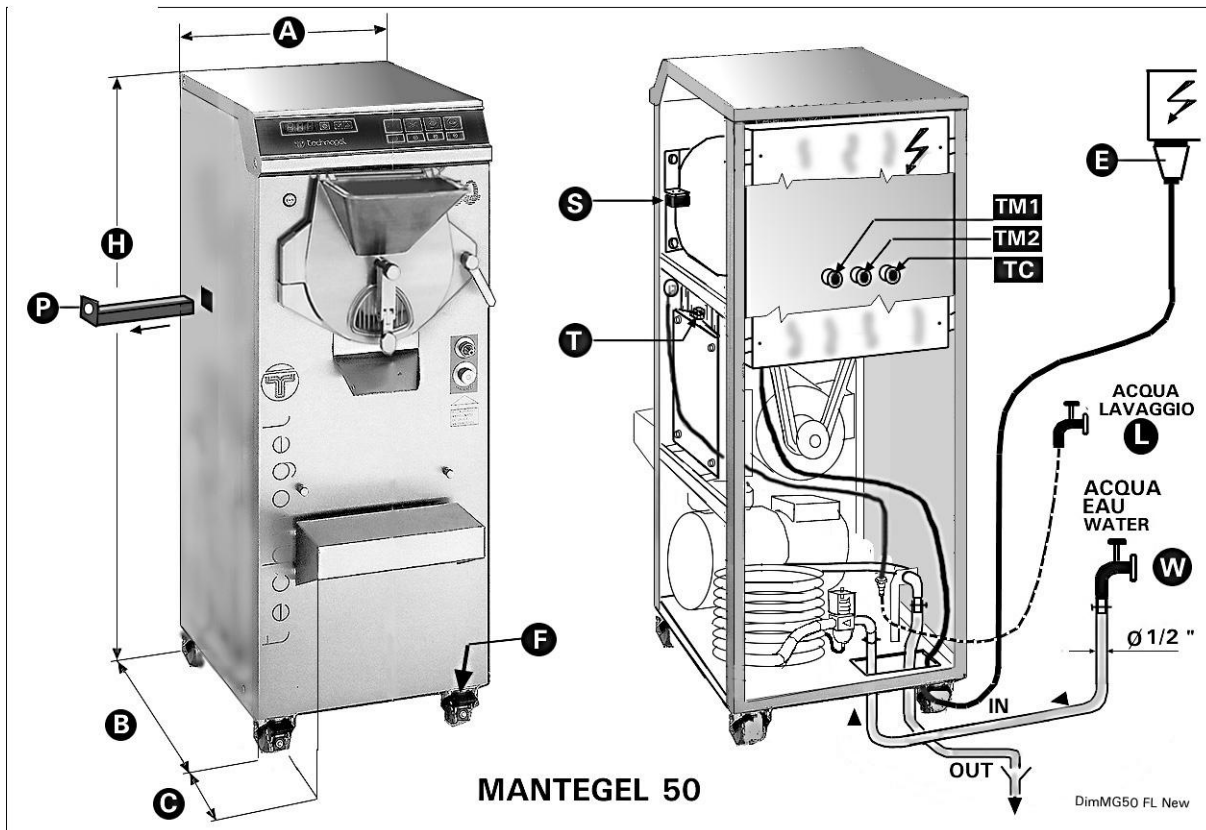

WARNING:

For the good functioning, the machine does not have to be anchored to the floor, neither some particular technical precaution are to be taken to limit the vibration transmission.

The installation requires the following operations:

- ⇒ Around the machine perimeter, leave an operative space of at least 10" (25 cm) necessary to carry out the works smoothly.
- ⇒ Make sure the machine is steady by blocking the brakes (F) of the front wheels using the feet (**DO NOT USE THE HANDS**).
- ⇒ Connect the hydro-system with the water inlet and outlet (see above picture point W). For the pressure and consumption data refer to page 12 (**MANTEGEL 50**). Connect, also, the washing water (L) cold or hot according to the availability.
- ⇒ Connect the electric system (see above picture point E). For the power and absorption data refer to page 10 (Table A - **MANTEGEL 50**).



Dimensions and different facilities: MANTEGEL 70

Dimensions and weight:

A – width	B – depth	C	H – height	Weight
19" 3/8	37"	7" 7/8	55"	960 Lb.
490 mm.	940 mm.	200 mm.	1400 mm.	435 Kg.

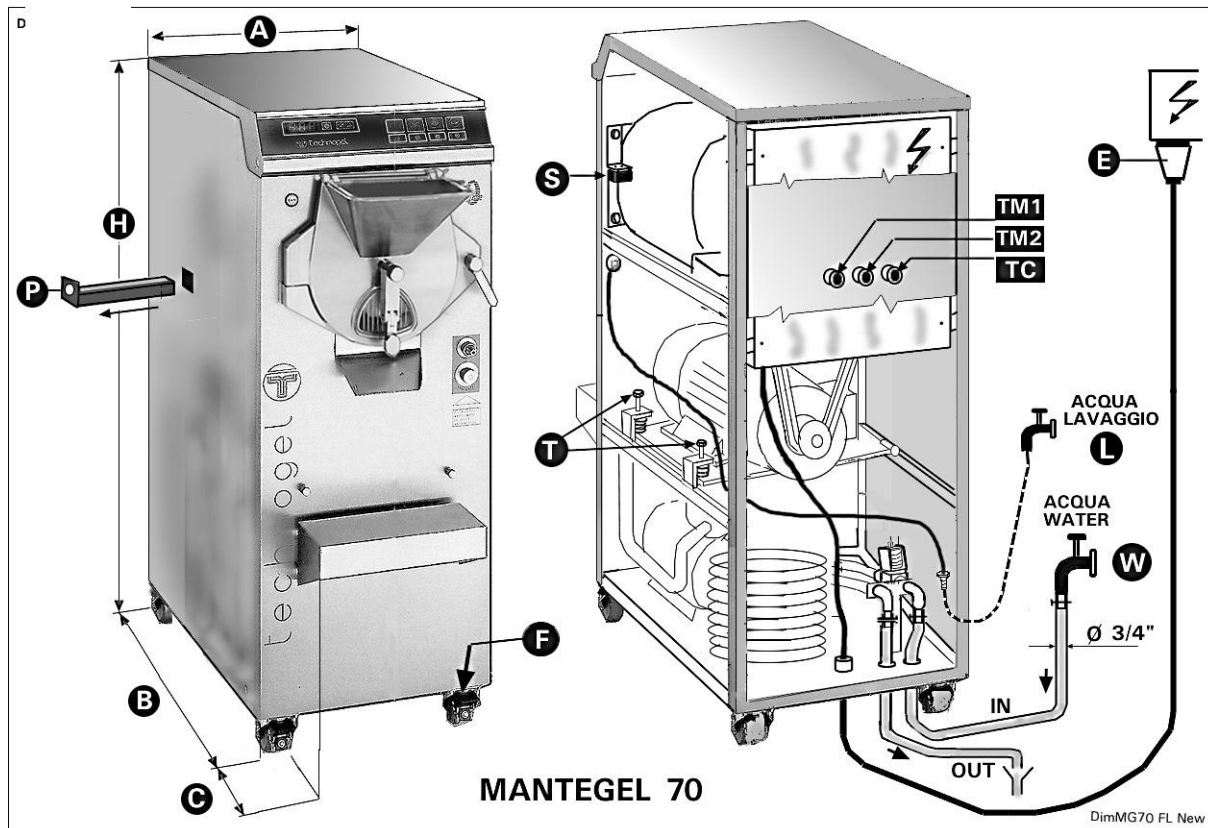

WARNING:

For the good functioning, the machine does not have to be anchored to the floor, neither some particular technical precaution are to be taken to limit the vibration transmission.

The installation requires the following operations:

- ⇒ Around the machine perimeter, leave an operative space of at least 10" (25 cm) necessary to carry out the works smoothly.
- ⇒ Make sure the machine is steady by blocking the brakes (F) of the front wheels using the feet (**DO NOT USE THE HANDS**).
- ⇒ Connect the hydro-system with the water inlet and outlet (see above picture point W). For the pressure and consumption data refer to page 12 (**MANTEGEL 70**). Connect, also, the washing water (L) cold or hot according to the availability.
- ⇒ Connect the electric system (see above picture point E). For the power and absorption data refer to page 10 (Table A - **MANTEGEL 70**).



Electrics installation

The electrical installation, which the machine is connected to, must be carried out by a **skilled electrician** according to regulations and observing the **Laws in force**. An efficient electrical installation with earthing is the most important thing in order for your machine to work perfectly.

Fit a suitable wall switch: we strongly recommend fitting an automatic differential switch. See table (A) for power rating and absorption details.

Check that the mains voltage rate is the same as the machine rating, shown on the serial number plate (see page 5).

The power cable has 4 wires: the **yellow/green** wire is the **earth** wire, the other three are for the three **phases**.

Table (A):

MANTEGEL 20		V.220 50HZ	V.220 60HZ	V.200 50/60HZ	V.380 50HZ	V.380 60HZ	V.415 50HZ
Total power	KW	2,6	2,6	4	2,6	2,6	2,6
Max. absorp.	A.	10,5	10,5	19	6,5	7,5	6,5
Power cable Wires & section		4 x 2,5 mm²	4 x 2,5 mm²	4 x 4 mm²	4 x 1,5 mm²	4 x 2,5 mm²	4 x 1,5 mm²

MANTEGEL 30		V.220 50HZ	V.220 60HZ	V.200 50/60HZ	V.380 50HZ	V.380 60HZ	V.415 50HZ
Total power	KW	4,2	4,2	4,2	4,2		4,2
Max. absorp.	A.	11,2	11,2	19,5	7	8	6,5
Power cable Wires & section		4 x 4 mm²	4 x 4 mm²	4 x 4 mm²	4 x 2,5 mm²	4 x 2,5 mm²	4 x 2,5 mm²

MANTEGEL 50		V.220 50HZ	V.220 60HZ	V.200 50/60HZ	V.380 50HZ	V.380 60HZ	V.415 50HZ
Total power	KW	6	6		6		6
Max. absorp.	A.	20	20		13		12
Power cable Wires & section		4 x 6 mm²	4 x 6 mm²		4 x 4 mm²		4 x 4 mm²

MANTEGEL 70		V.220 50HZ	V.220 60HZ	V.200 50/60HZ	V.380 50HZ	V.380 60HZ	V.415 50HZ
Total power	KW	11,2	11,2	11,2	11,2		11,2
Max. absorp.	A.	36	36	45	21		20
Power cable Wires & section		4 x 10 mm²	4 x 10 mm²	4 x 10 mm²	4 x 6 mm²		4 x 6 mm²

**TECHNOGEL CANNOT BE HELD LIABLE FOR ANY DAMAGE ARISING FROM
INCORRECT INSTALLATION OR MAINS DEFECTS.**



Water connection

The refrigeration system has a water-cooled condenser. A connection for the hot or cold water pipe exists. It is useful for washing the machine. Its tap and nozzle are in the front of the machine.

Connect the mains hose to the fitting that reads " **ENTRATA ACQUA- WATER INLET** ".
The drain hose must be connected to the fitting that reads " **USCITA ACQUA-WATER OUTLET** ".

The connection plates and fittings are inside the machine: to access these, remove the rear panel.

To connect the machine to the mains, we recommend using a rubber hose suitable for up to **10 bars** with an inside diameter of about 15 mm (matching the fittings supplied with the machine).

If, for any reason, the plates indicating water inlet and outlet are illegible, please note that the water inlet hose is fitted to the pressure-switch valve.

WATER PRESSURE AND CONSUMPTION

If the machine is using mains water, check that the incoming water has a pressure of at least **1 bar**.

If the water pressure is more than **5 bar**, fit a pressure reducer to the system, to reduce this to **4 bar**.

Average water consumption (when the refrigerating unit is on) is:

- **MANTEGEL 20 = 80/100 litres/hours***

- **MANTEGEL 30 = 100/190 litres/hour***

- **MANTEGEL 50 = 150/250 litres/hours***

- **MANTEGEL 70 = 300/450 litres/hours***

* depending on the temperature of the incoming water.

If the water contains impurities, fit a purifying filter to avoid scaling and/or damage to the pressure-switch valve.

MACHINE POSITIONING CONDENSER FOR AIR O AIR / WATER CONNECTIONS

Technician qualificate:

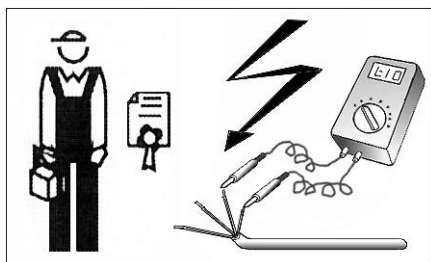

ELECTRICIAN

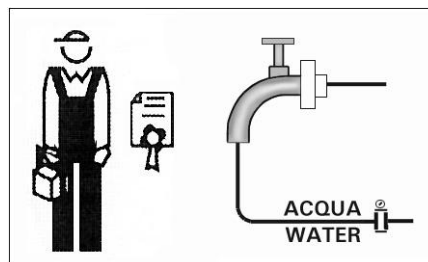

PLUMBER

IF The machine works with isolate condenser, you' ll have to contact the:

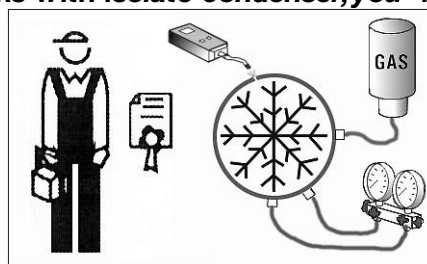

REFRIGERATOR TECHNICIAN

Positioning of machine with fixed air condenser

VALID FOR MACHINES WITH EITHER AIR CONDENSATION OR AIR/WATER COMBINED

It is extremely important that the machine should be installed in a spacious room with doors and windows so the air heated by the machine can be changed regularly.

The rear of the machine must be placed at a distance of at least 0.5 metres from the wall.

During operation of the machine, the doors and windows in the room must be left open otherwise the air heated by the machine will become extremely hot and could reach temperatures of around **50°C**. If the machine is allowed to operate in these conditions the main components (refrigerator compressor and turbine motor) could well overheat over the long term and this could jeopardize correct operation of the machine and cause damage which would be costly to repair. It would also mean an increase in running costs owing to the high consumption of electricity while the machine's performance would be reduced by 50%.

IDEAL POSITIONING OF THE MACHINE

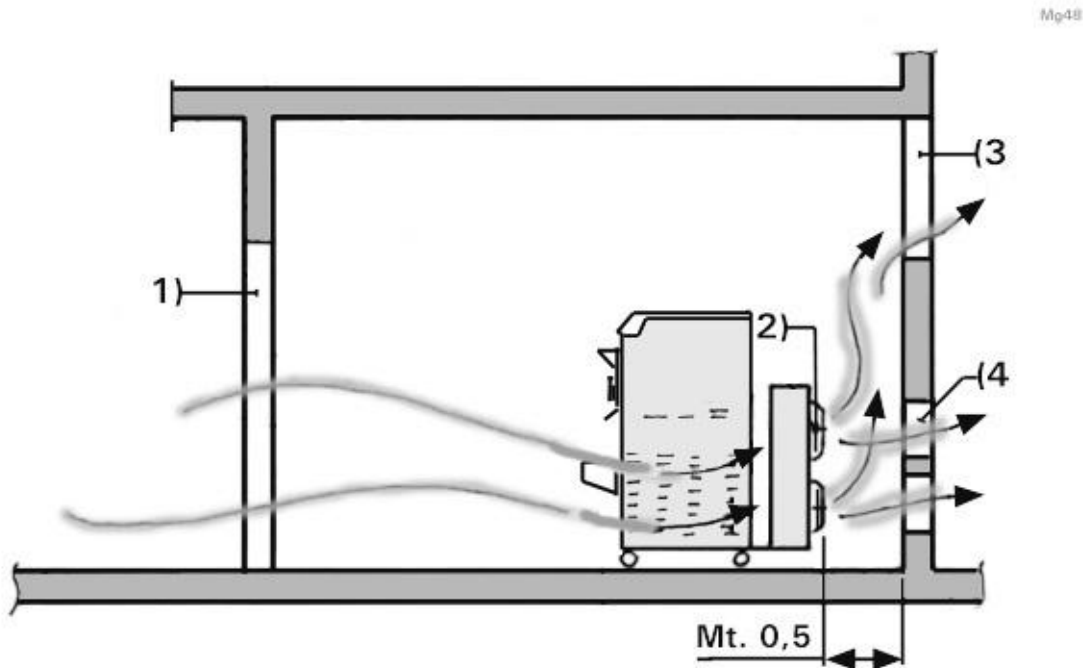

As shown in the diagram, the air coming in through the door (1) is sucked in and heated during condensation of the ventilators (2) and is pushed in the direction of the window (3) and thus outside.

The ideal solution, though not always easy to put into practice, is to make holes in the wall (4) opposite the ventilators (2). The air can therefore flow out freely without any problem and the machine's performance will always be excellent.

TECHNOGEL spa CANNOT BE HELD RESPONSIBLE FOR ANY DAMAGE CAUSED BY INCORRECT POSITIONING OF THE MACHINE IN AN UNSUITABLE PLACE. THE COMPANY IS ALSO UNABLE TO ASSUME ANY RESPONSIBILITY FOR INADEQUATE PERFORMANCE OF THE MACHINE OWING TO OPERATING CONDITIONS BEING BEYOND THE LIMITS OF ACCEPTABILITY.

Positioning of the machine with remote air condenser

In order to combat problems of overheating of the air, whenever possible the remote air condenser should be mounted.

CAUTION:

Copper or flexible piping (T) transporting the refrigerant gas from the machine to the condenser and vice versa, should not exceed 4 metres in length.

The condenser must be fixed to wall brackets positioned high up so that they are beyond the reach of people of average height.

As illustrated in the diagram, the condenser must be positioned at least 200 mm from the wall so that air can be sucked in without any problem. It is also advisable to install protective roofing over the equipment to protect it from rain water.

with remote air condenser

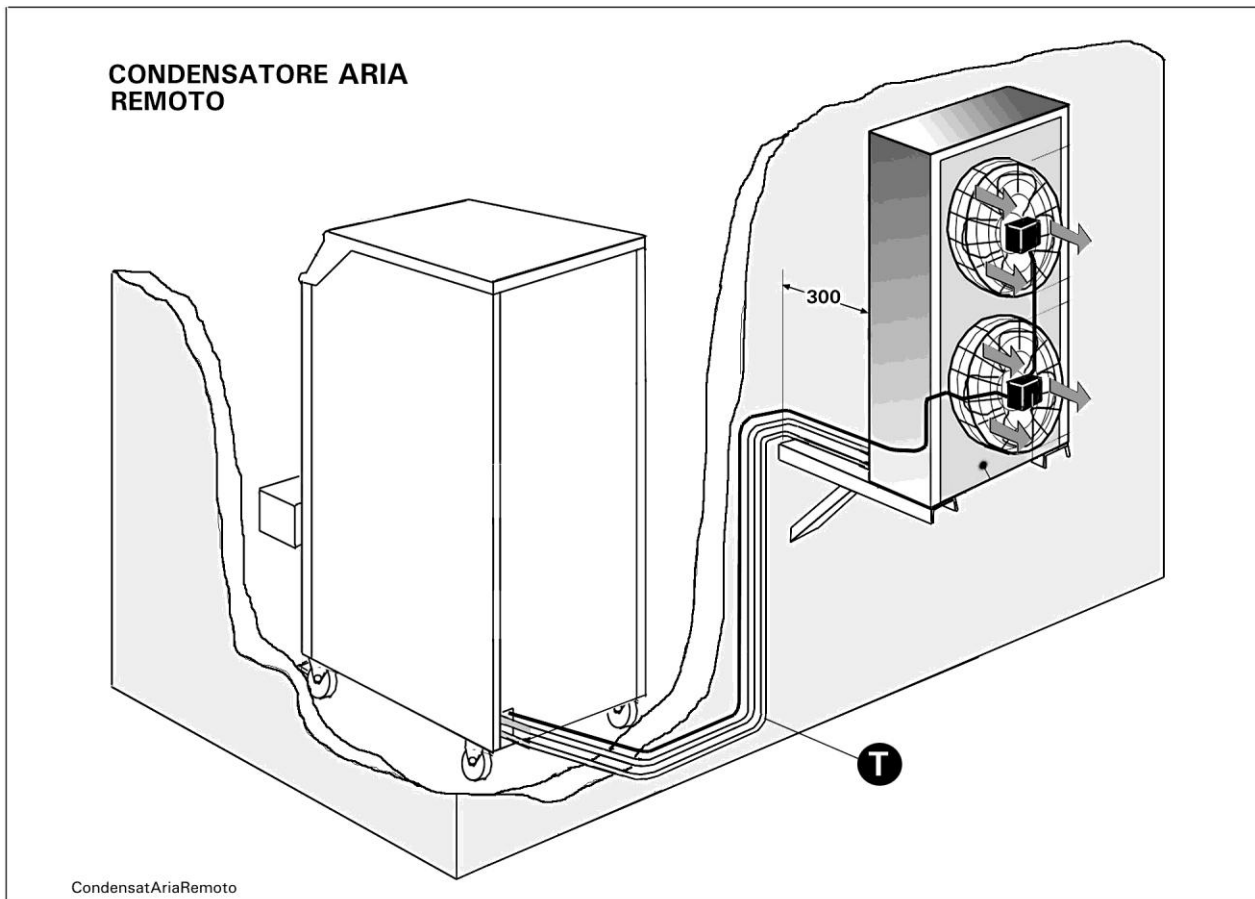

The machine must be installed by a Refrigeration Technician who after connecting the equipment will check that the quantity of gas inside the machine is correct for optimum operation.

Cooling Machine fixed

Dimension / Weigh **MANTEGEL 20 Air**

A- Width	B – Depth	C – Console Table	H – Height	Weight
490 mm	1120 mm	200 mm.	1305	220 Kg.

Dimension / Weigh **MANTEGEL 30 Air**

490 mm	1120 mm	200 mm.	1305	250 Kg.
--------	---------	---------	------	---------

Dimension / Weigh **MANTEGEL 50 Air**

490 mm	1300 mm	200 mm.	1305	290 Kg.
--------	---------	---------	------	---------

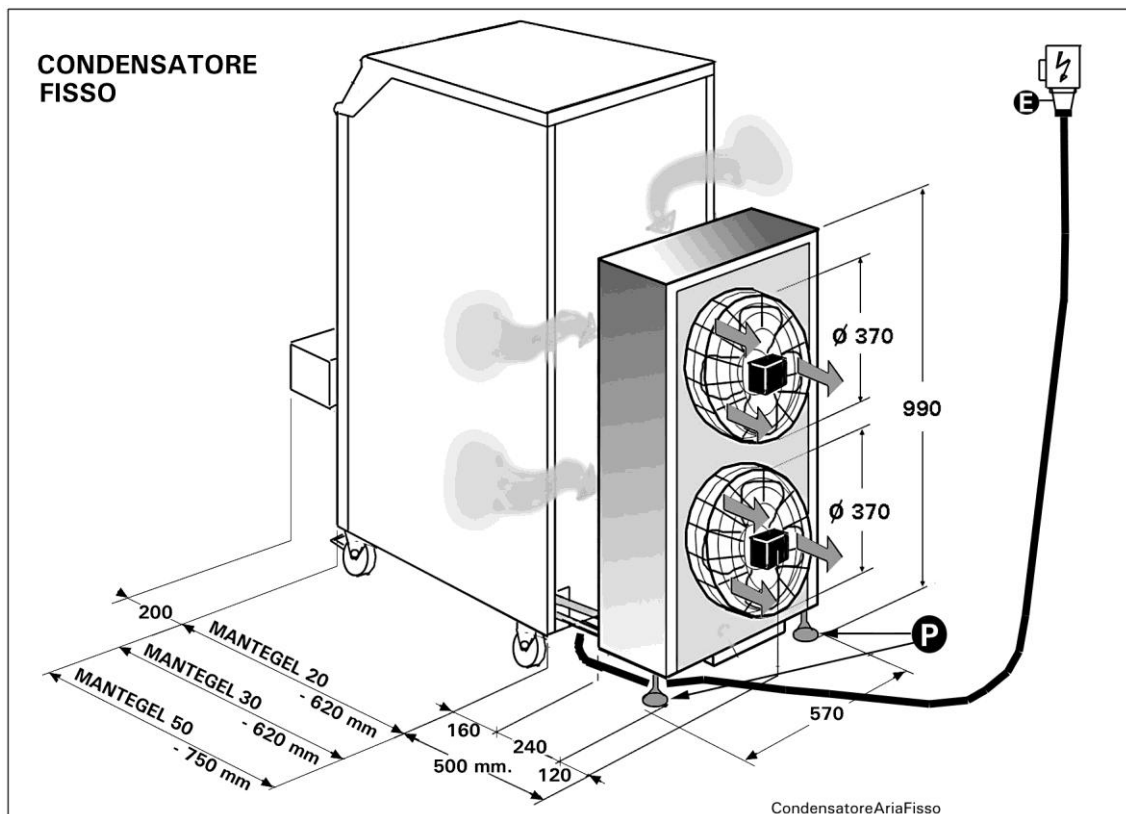

WARNINGS:

After positioning the machine and locking the front wheels by pressing on the brake with the feet (**do not use the hands for this operation**), check that the feet (P) both rest on the floor. If the feet (P) are not level, during operation the condenser could move around owing to movement of the ventilators.

- ⇒ If the machine operates in contact with other machines, make sure there is a space of at least 25 cm between them.
- ⇒ Carry out the **electrical** connections of the machine and make sure that the electric cable (E) comes from above and is not laid on the floor where it could be crushed. For data on power and absorption please see page 22 Table A under the specific machine reference.
- ⇒ For the **MANTEGEL 30** and **MANTEGEL 50 machines**, it is possible to connect hot or cold water for washing purposes to the rear of the machine.

Cooling Machine Arranged air water

Dimension / Weigh **MANTEGEL 20 Air / Water**

A - Width	B - Depth	C - Console Table	H - Height	Weight
490 mm	1120 mm	200 mm.	1305	230 Kg.

Dimension / Weigh **MANTEGEL 30 Air / Water**

490 mm	1120 mm	200 mm.	1305	260 Kg.
--------	---------	---------	------	---------

Dimension / Weigh **MANTEGEL 50 Air / Water**

490 mm	1300 mm	200 mm.	1305	300 Kg.
--------	---------	---------	------	---------

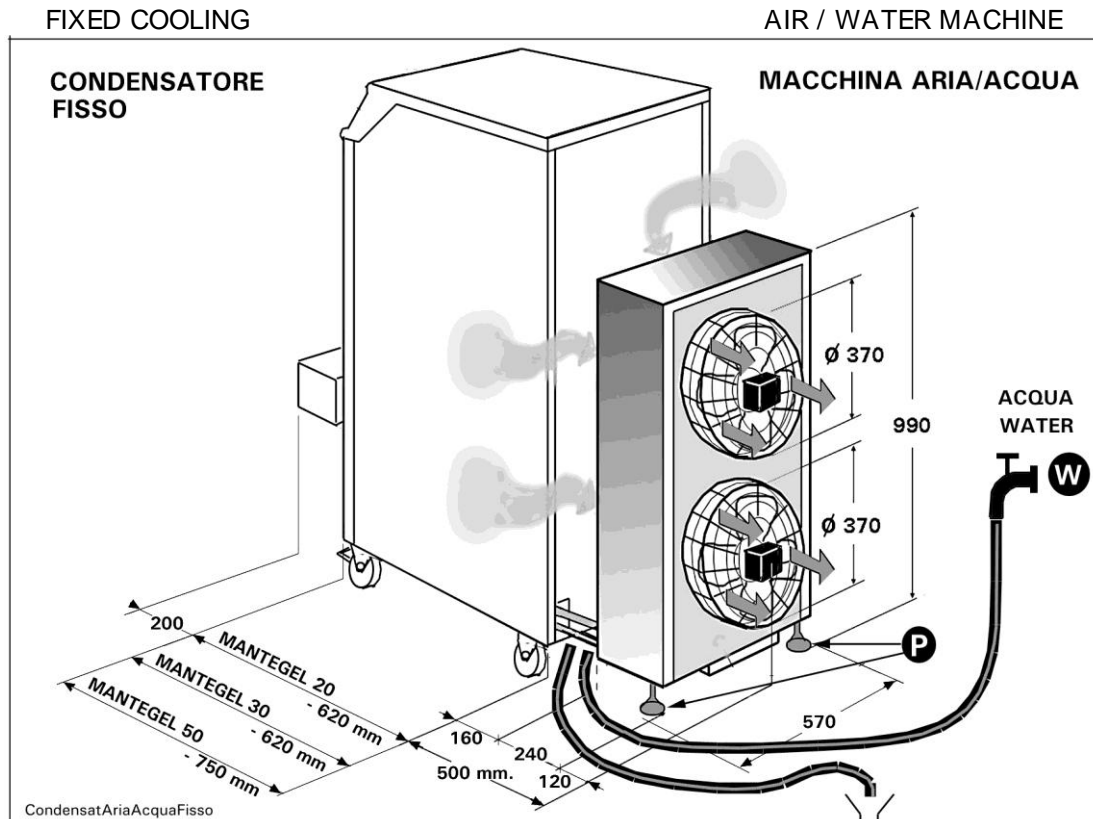

WARNINGS:

After positioning the machine and locking the front wheels by pressing on the brake with the feet (**do not use the hands for this operation**), check that the feet (P) both rest on the floor. If the feet (P) are not level, during operation the condenser could move around owing to movement of the ventilators.

- ⇒ If the machine operates in contact with other machines, make sure there is a space of at least 25 cm between them.
- ⇒ Carry out the **electrical** connections of the machine and make sure that the electric cable (E) comes from above and is not laid on the floor where it could be crushed. For data on power and absorption please see page 22 Table A under the specific machine reference.
- ⇒ Connect the **water supply** (W) to the machine with inlet and outlet for the condensation from the refrigerating unit. For instructions on how to connect the machine, please see pages 8, 9 or 10 depending on the type of machine. For data on pressure and consumption, please see page 15. (Page 19 only).
- ⇒ For the **MANTEGEL 30** and **MANTEGEL 50 machines**, it is possible to connect hot or cold water for washing purposes to the rear of the machine.



Electric installation

COOLING MACHINE AIR O AIR / WATER

The electrical installation, which the machine is connected to, must be carried out by a **skilled electrician** in compliance with regulations and the Laws in force. An efficient electrical installation with earthing is most important to ensure your machine works perfectly.

Fit a suitable wall switch: we strongly recommend fitting an automatic differential switch. See table (A) for power rating and absorption details.

Check that the mains voltage is the same as the machine rating, shown on the serial number plate (see page 6).

- When the cable has **4** wires, the **yellow/green** wire is the earth and the other three are the three **phases**.
- When the cable has **5** wires, the **yellow/green** wire is the earth - the **blue** wire is neutral - the other three are the three **phases**.

- TABLE -A-

MANTEGEL 20 Air		V.220 50 HZ	V.220 60 HZ	V.400 50 HZ	V.380 60 HZ
Total power	KW.	3	3	3	
Absorbtion edge	A.	12	12	8	
Wire line					
Branch screw		4 x 2,5mm²	4 x 2,5mm²	4 x 1,5mm²	

MANTEGEL 30 Air		V.220 50 HZ	V.220 60 HZ	V.400 50 HZ	V.380 60 HZ
Total power	KW.	3,2	3,2	3,2	
Absorbtion edge	A.	13	13	8,5	
Wire line					
Branch screw		4 x 4mm²	4 x 4mm²	4 x 2,5mm²	

MANTEGEL 50 Air		V.220 50 HZ	V.220 60 HZ	V.400 50 HZ	V.380 60 HZ
Total power	KW.	5,2	5,2	5,2	
Absorbtion edge	A.	21	21	14,5	
Wire line					
Branch screw		4 x 6mm²	4 x 6mm²	4 x 4mm²	

**TECHNOGEL spa CANNOT ASSUME ANY RESPONSIBILITY FOR ACCIDENTS
 CAUSED BY IMPROPER INSTALLATION OR FAULTY WIRING**

ACCEPTABLE AND UNACCEPTABLE USAGE

ACCEPTABLE AND UNACCEPTABLE USAGE

All whipping machines in TECHNOGEL's **MANTEGEL** series have been designed exclusively for mixing ice-cream.

Use of these machines for any products other than those intended is entirely at the Customer's own risk.



⇒ Machine operation conditions

Below are the minimum and maximum mix loads that the different machines can work (expressed in litres of mix per load).

	minimum load	maximum load
MANTEGEL 20	2 litres	4 litres
MANTEGEL 30	3 litres	6 litres
MANTEGEL 50	3 litres	8 litres
MANTEGEL 70	7 litres	15 litres

WE STRONGLY RECOMMEND RESPECTING THESE MINIMUM AND MAXIMUM LOADS TO ENSURE THAT YOUR MACHINE PRODUCES GOOD QUALITY ICE-CREAM IN ABSOLUTE SAFETY.

⇒ Initial start-up



CAUTION IMPORTANT

TO CARRY OUT INITIAL START-UP, PRESS THE “ START” BUTTON AND THEN WAIT FOR AT LEAST 60 MINUTES BEFORE ACTIVATING THE REFRIGERATOR COMPRESSOR.

IF THE MACHINE IS DISCONNECTED FROM THE POWER SUPPLY FOR ONE DAY OR MORE, AFTER PRESSING THE “ START” BUTTON, IT IS NECESSARY TO WAIT FOR AT LEAST 60 MINUTES BEFORE ACTIVATING THE REFRIGERATOR COMPRESSOR.

IF THE MACHINE IS NEVER DISCONNECTED FROM THE POWER SUPPLY NO WAITING PERIOD IS NECESSARY.



Safety warning

Before starting the machine, verify if the safety devices (1) (hopper protection grill) and (2) (exit protection grill) are mounted and working.



WARNING

Tampering or reducing the safety devices (1) and (2),
can cause serious injuries to the operator

What you must not do while the machine is operating:

Never introduce foreign bodies in the hopper when this is in use, eg.
scrapers -
knives - rubber hose, etc., as these can damage the machine and may
injure the operator.

Never put scrapers or knives between the bars in the exit while the ice-
cream is flowing out.

TECHNOGEL CANNOT BE HELD LIABLE FOR DAMAGE AS A RESULT
OFTAMPERING WITH THE MACHINE SAFETY DEVICES.

FUNCTIONS OF THE MACHINE WITH PRELIMINARY CHECKING AND CONTROL

The explanation of the machine functions, preliminary checking and controls should be carried out by TECHNOGEL' s Technician together with the Operator who will be using the machine after appropriate training has been given.

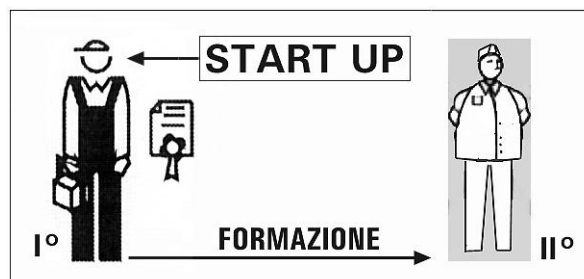

Console control functions – **GEL – batch freezing**

➤ Instructions for setting the texture of the ice-cream:

To set the ice-cream hardness, first connect the control console to the power supply by pressing the **START** button. The pushbutton must be lit up.

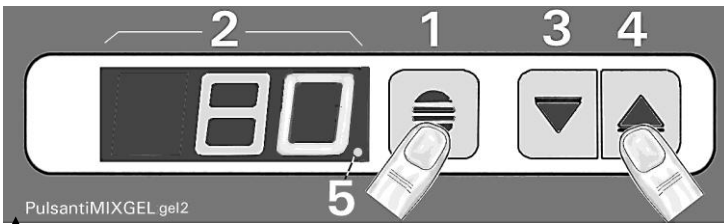

The number (expressed as a percentage) which appears on the display (2), indicates the force exerted by the turbine in mixing the ice-cream and can vary from **0%** (mixer turbine motor stopped) to **60%** (motor in operation with liquid mixture) to **100%** (maximum force the motor can produce).

This number varies (the value rises) the thicker the texture of the ice-cream: i.e. the harder the ice-cream, **the higher the number indicated on the display**.

This value when the ice-cream is ready can range from **70** to **100%** depending on the model (MG20 – MG30 – MG50 – MG70). The right value for your machine will be obtained by experimenting with a first freeze-batch.

Whilst holding down key (1), press key (4) until the display gives the maximum value (**100**). Carry out a “batch freeze” and when the ice-cream is to your liking look on the display to see the number indicated (e.g. **78**). While the machine is in operation, hold down key (1) and press key (3) so that the value on the display, regulated on **100**, drops to tally with the number read for the ice-cream prepared (**78**). The LED (5) will flash intermittently for 1.5 seconds and immediately afterwards you will hear an alarm sound (different from the pasteurization alarm). It will sound for 10 seconds to warn you that the ice-cream is ready for extraction (while the alarm is sounding the freezing stops whereas stirring continues). If the ice-cream is not extracted the machine will start to freeze again and will once again reach the hardness value set. At this point it will stop, the alarm will sound again as described above, and the process will then continue indefinitely.

This is the right texture for your ice-cream and the machine will then repeat it endlessly, without any need to reset it each time.

If during subsequent batch freezings the ice-cream does not seem hard enough, or is too hard, the hardness value can be regulated even when the machine is in operation. Hold down key (1), increase the value to (**80**) using key (4) (to get harder ice-cream) or decrease to **76** using key (3) (to get softer ice-cream).

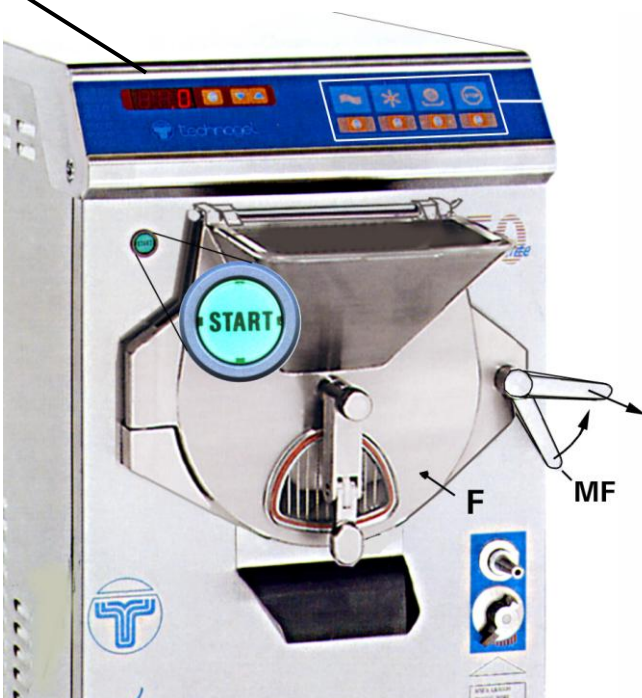

Generally speaking it is normal for the hardness parameters to vary slightly from cream flavoured ice-cream to fruit ice-cream and from minimum to maximum quantities frozen.

CAUTION:

When varying the hardness **never change the value by more than 2% at a time**.

Depending on the model of machine (MG20 – MG30 – MG50 – MG70) or the type of mix which is to be frozen, it is possible and quite normal for a value to be set which is too high for the machine to reach, even though the value is below 100. If this occurs, read the maximum value achieved and set this value as the hardness for that particular type of ice-cream.

Control console functions –

Control keyboard

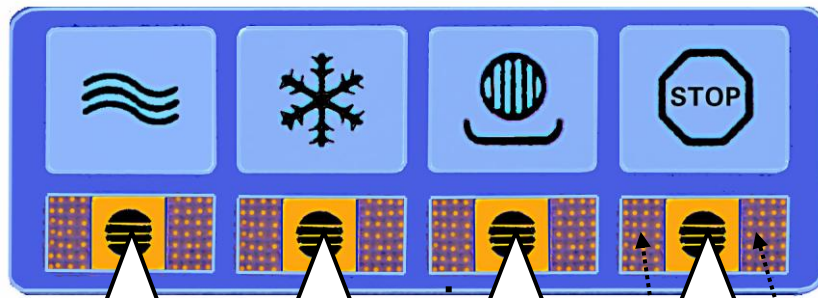

WASHING key:
press this key to start the stirrer motor at high speed.
It will stop automatically after 20 seconds.

ICE CREAM Key:
press to produce ice-cream.
Start-up of the stirrer motor at low speed and the refrigeration compressor are separate. The stirrer motor starts first and then after a few seconds the refrigerator compressor is activated.

STOP key:
when the console is connected to the power supply this key automatically lights up
Press this key to stop the machine at any time.

ICE CREAM OUTLET Key:
press this key to empty the machine of ice-cream rapidly.
In this position the stirrer motor rotates at high speed.
In this position the refrigerator compressor will not operate.



CAUTION:

If the **(START)** button is not connected (light on), the keyboard and display remain off.

If the flange handle **(MF)** is not properly closed, the keyboard will not turn on and will not accept commands.

If flange **(F)** is open, the keyboard will remain off and will not accept commands.

Console control functions

Instructions for changing Operational for ice-cream production on the machine

- “**ITA**” Mode (Standard most commonly-used Mode) :

When you press the ICE-CREAM key the mixer turbine will rotate at low speed.



How to insert “**ITA**” Mode :

Press key **4** for four seconds and display **2** will give “**ItA**” .
Release key **4**, and the operational Mode is memorized.

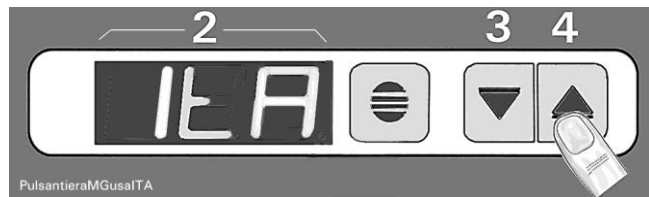

ItA

- “**USA**” Mode :

When you press the ICE-CREAM key the mixer turbine will rotate for about 10 seconds at low speed, for about 3 minutes at high speed and again at low speed till the end of the cycle.



How to insert “**USA**” Mode :

Press key **3** for four seconds and display **2** will give “**USA**” .
Release key **3**, and the operational Mode is memorized.



USA

CAUTION:

For each Mode, **ItA** or **USA**, set the texture of the ice-cream you wish to produce as described on page 20.

Before starting production, press the appropriate key (3) or (4) to find which Mode has been set.



Machine start-up:

CAUTION IMPORTANT

FOR INITIAL START-UP, PRESS THE “START” BUTTON AND WAIT FOR AT LEAST **60 MINUTES** BEFORE PRESSING ANY KEYS.

IF THE MACHINE IS DISCONNECTED FROM THE POWER SUPPLY FOR ONE OR MORE DAYS, IT WILL BE NECESSARY TO PRESS THE “START” BUTTON AND THEN WAIT FOR **30 MINUTES** BEFORE PRESSING ANY KEY WHATSOEVER.

IF THE POWER SUPPLY IS NEVER DISCONNECTED FROM THE MACHINE IT CAN BE STARTED WITHOUT HAVING TO WAIT FOR ANY PERIOD OF TIME.

⇒ Checking efficient operation of safety device on front door

- 1) **Disconnect the power supply** to the control console by pressing the **START** button (**light off**)
- 2) Open the front door (**F**) by rotating the handle (**MF**) anticlockwise and then pull towards the outside.



- 3) Extract the dasher (1) by grasping it by the spokes and pulling outwards.

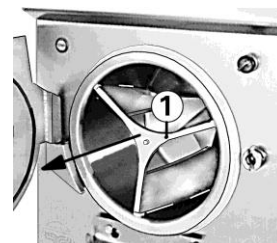

- 4) Reconnect the power supply by pressing the **START** button (**light on**).

- 5) Press the **ICE-CREAM** key and check the bottom of the freezing chamber. In the centre you will see the triangular dasher device (2).



IF THE TRIANGULAR DASHER DEVICE (2) DOES NOT ROTATE, THIS MEANS THAT THE SAFETY DEVICE IS ACTIVATED AND IN OPERATION

- 6) Close the front door (**F**) once again and lock with the handle (**MF**). The control console will light up switching to **STOP**.

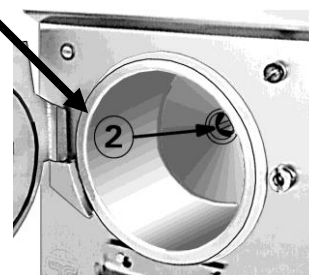

When carrying out periodic controls, if the device is not operating, please call the Technical Assistance Service immediately.

CAUTION:

The device is designed to operate only in emergencies when the front door (**F**) is opened before the machine has been stopped using the **STOP** key.



Checking the direction of rotation

When the machine is empty:

Connect the console to the power supply using the **START** switch.



Checking from the hopper of front door (**F**), press the **ICE-CREAM** key and immediately after the **STOP** key

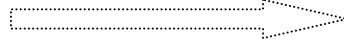

The dasher which mixes the ice-cream must rotate **anticlockwise**; if it fails to do so:

- 1 – Disconnect the power supply to the console by pressing key (**IG**).
- 2 – Detach the machine cable from the power supply and invert any two of the three phases.
- 3 – Reconnect the power supply and try again.

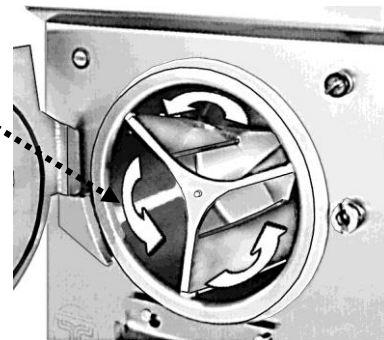

TECHNOGEL spa, CANNOT BE HELD RESPONSIBLE FOR ANY DAMAGE CAUSED BY IMPROPER USE OF THE MACHINE OR BY INCORRECT INSTALLATION DUE TO HASTE AND/OR NEGLIGENCE.

CHECKING THE SAFETY DEVICES AND ENSURING THEIR CORRECT OPERATION MEANS THAT THE OPERATOR CAN BE SECURE IN THE KNOWLEDGE THAT NO RISK IS INVOLVED IN HIS WORK.

INITIAL START-UP WITH THE ICE- CREAM MANUFACTURING MACHINE

Initial start-up must be carried out by an Authorized Technician.

The user must be trained by the Authorized Technician so that after appropriate hands-on training he will be able to operate the machine without any problem.

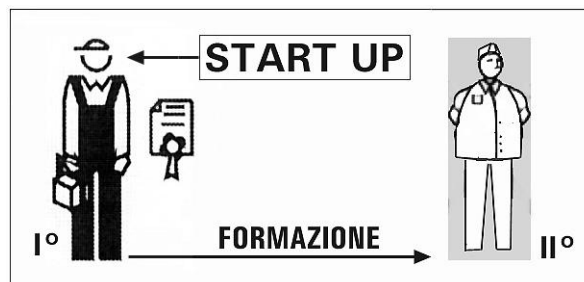

Verify the batch freezer dasher

Before starting production, dismantle and check the dasher and all its components.

Cut off the tension to the control console pressing the "Start Key". (Light off)

Open front door (F) turning the handle (MF) anticlockwise and pull it towards you.



Extract the dasher (1), holding it by the spokes and pull it outwards.

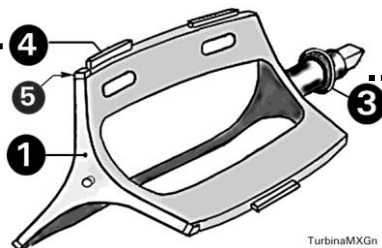
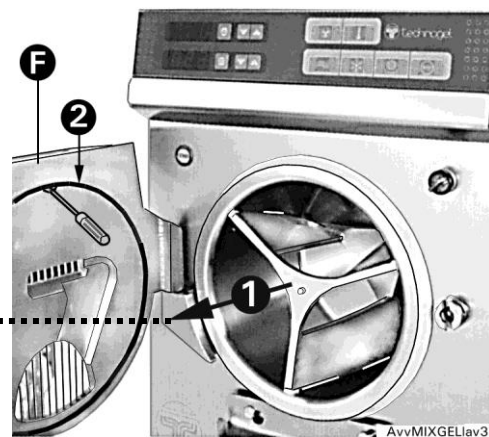

TurbinaMXGn

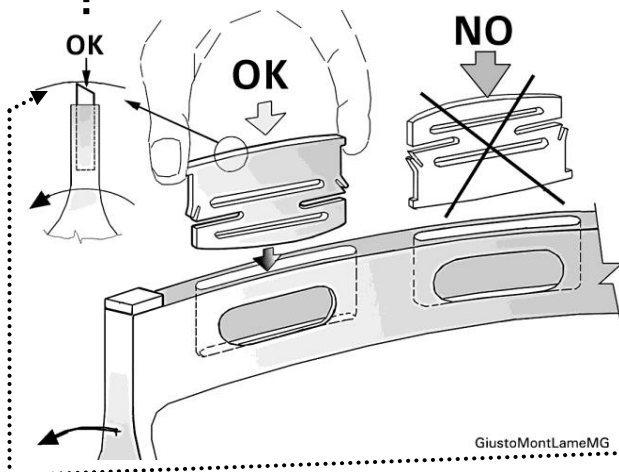

Check that the turbine is fitted with a packing gland (3), scraper blades (4) and turbine centre pads (5). If these pieces are consigned separately in an envelope (they are dismantled for transportation), mount them on the turbine.

Packing gland (3): slide it onto the end of the dasher, it does not have a specific seat) as shown in the diagram. Grease first with solid Vaseline.

Dasher centre pads (5): there are three of these and they must be placed in the appropriate slots, one for each dasher spoke.

Scraper blades (4): mount these as shown in the diagram at the side. They must be free to carry out their spring movement without hindrance.

Check the direction of scraping action.

Suggestion:

- After each washing operation and if the machine remains out of use for any period of time, dismantle the packing gland (3) and scraper blades (4) leaving the turbine centre pads in place (5). Reassemble the various pieces just before re-starting production and make sure they are in good condition.

Machine operation

the first time



then



1. Connect the console to the power supply using the **START** switch.
2. Pour the ice-cream mix into the hopper. For maximum and minimum quantities please see page 24.
3. Check the setting for the hardness desired (e.g. **78**). See page 28.

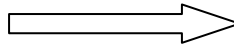

When the mix that is poured into the machine turns into ice-cream, it will increase in volume by between **30/40%**.

 This must be taken into account when organizing containers to be filled.

4. Press the **ICE-CREAM** key to start batch freezing. **78%**



4. Press the **ICE-CREAM** key to start batch freezing.
5. After a few minutes the ice-cream will reach the hardness value set, the compressor will stop (while the turbine mixer continues to rotate) and an acoustic warning signal will sound for 10 seconds to inform the operator that the ice-cream is ready to be extracted. If the ice-cream is not extracted, after a stoppage of 10 seconds the refrigerating compressor will start working again and will once again take the ice-cream to the hardness value set.



6. To extract the ice-cream, release by lifting and pulling the knob on the lever (PL) and then press the key **ICE-CREAM EJECTION**.



For MANTEGEL 20:
 When this key is pressed, the speed of the stirrer motor remains the same.
 The refrigerator compressor stops.

7. Once extraction is completed, press the **STOP** key and close the ice-cream outlet with the knob (PL).



For MANTEGEL 30 – 50 – 70:
 When this key is pressed the stirrer motor starts at high speed for rapid and complete ejection of the ice-cream.
 The refrigerator compressor stops.

Suggestions:

- Start batch freezing the lightest coloured flavour and finish with the darkest flavour. This means it will not be necessary to wash the machine between one flavour and another.
- Once the ice-cream is ready to extract, **never** put on **STOP** and then **ICE-CREAM EJECTION**. Go directly from the **ICE-CREAM KEY** to **ICE-CREAM EJECTION**.
- If you are producing more than one tank at a time, we recommend extracting the first tank on **ICE-CREMA** position and then the others on **ICE-CREAM EJECTION**.

OPERATION OF MACHINE WITH “ *GRANITA* ” DEVICE

This section only applies to machines fitted with the “Granita” device

Description of “Granita” device

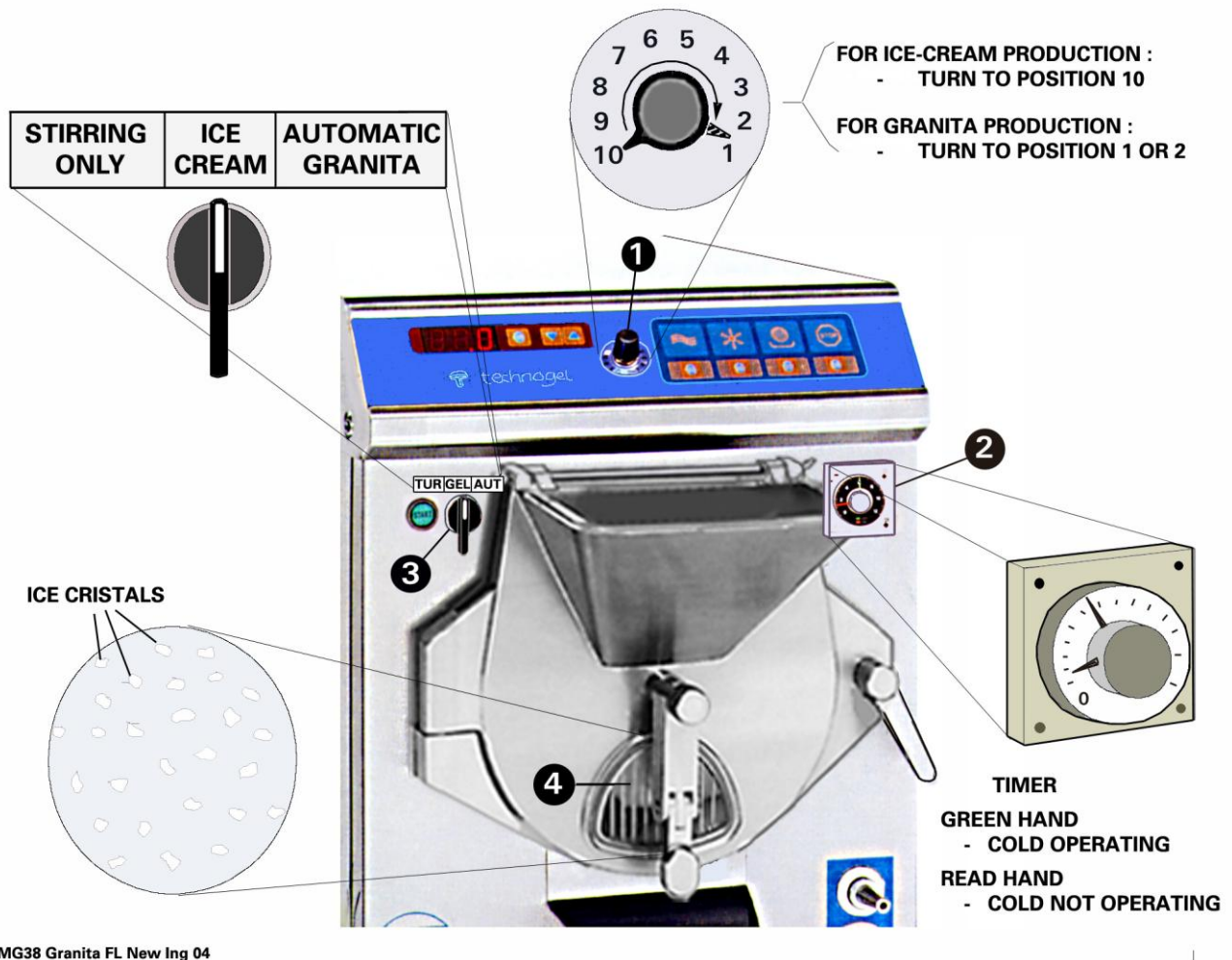

The machines described up to this point can be fitted with a special device for the production of classic “**Sicilian Granita**”.

Besides all the standard components which form part of the different machines, the following additional parts are required:

- **INVERTER** for the stirrer motor (positioned inside)
- **POTENTIOMETER (1)** to regulate the rotations of the stirrer using the Inverter
- **TIMER (2)** to ensure intermittent control for the amount of cold required
- **KNOB (3)** to select the options available for operation of the machine

⇒ Machine operation for production of “ice-cream”

To produce ice-cream, position the **Potentiometer (1)** on 10 and turn the **Knob (3)** to **Ice-cream**.

From this point on, follow the instructions described on the previous pages..

Operation of the machine for production of “Granita”

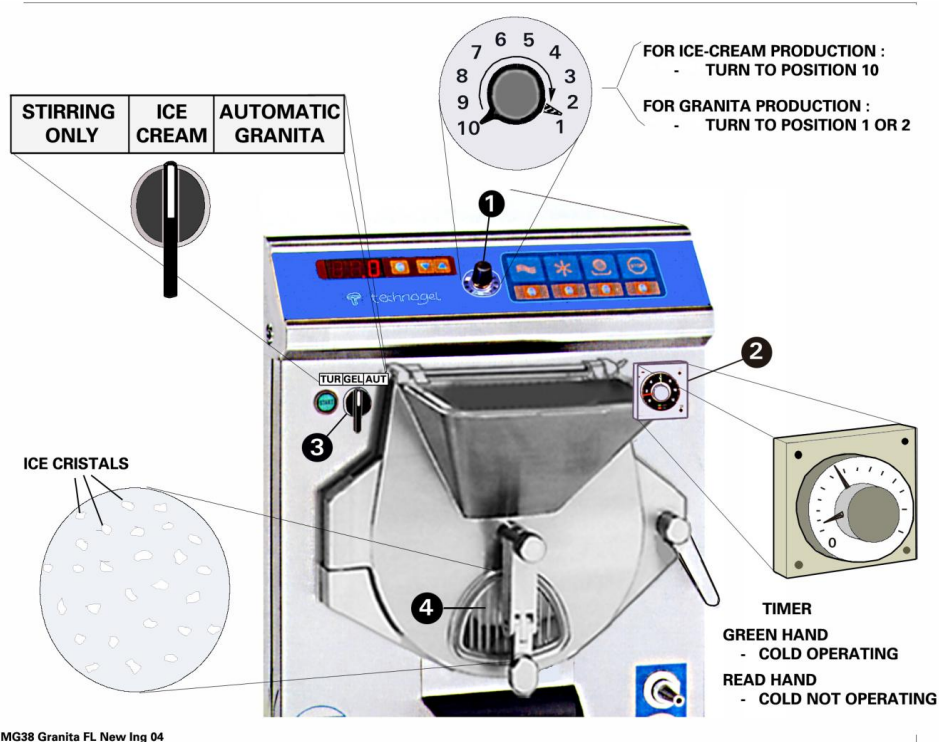

1. Before starting the machine, turn the **Potentiometer (1)** to **1.5**.
2. Turn the **Knob (3)** to **Ice-cream**
3. Leave hardness adjustment as for ice-cream.
4. Regulate the **Timer (2)** to **10 seconds (green hand)** and **20 seconds (red hand)**.
5. Pour in the mix from the hopper (minimum and maximum quantities are as for ice-cream).
6. Press the **ICE-CREAM** KEY.
7. While the machine is in operation, check through the transparent plate (**4**) and wait for the mix to start forming **ice crystals**.
8. At this point, turn **Knob (3)** to the **AUTOMATIC GRANITA** position. In this position the machine will operate intermittently: the mixer turbine operates constantly while the refrigerating compressor operates for 10 seconds and stops for 20.
9. When the granita appears to be ready, turn **knob (3)** onto the **STIRRING ONLY** position, open the ejection plate and allow the granita to emerge slowly.
10. When the granita has come out, press the **STOP** key.

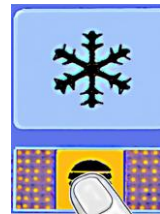
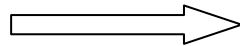

THESE TIMES ARE APPROXIMATE AND CAN BE LENGTHENED OR SHORTENED DEPENDING ON THE TYPE OF GRANITE REQUIRED

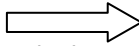

PER FARE USCIRE LA GRANITA, NON PREMERE MAI QUESTO TASTO

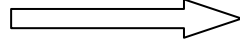

CAUTION:

No two types of **granita** are the same and so there is no standard method of production. Each customer will find the method he or she considers best by varying the parameters given above (**stirring speed – large or small ice crystals – cold and pause times – when to stop and remove the product from the machine**).

WASHING THE MACHINE



Washing the machine

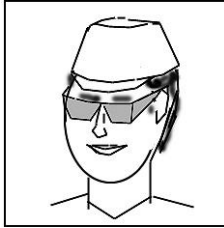

**DURING THE OPERATIONS FOR WASHING AND
SANITIZING THE MACHINE, WEAR THE
PROTECTION DEVICES INDICATED:**

GLASSES AND RUBBER GLOVES.

**(USE RUBBER GLOVES WHICH COVER THE
WHOLE FOREARM)**

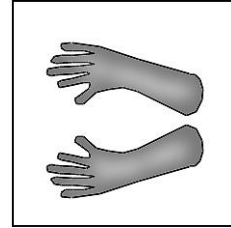

- 1) Before starting the washing operations make sure the machine is unplugged.
- 2) Open the lid and rinse the tank with hot water at a temperature of 50°:60° C and then drain off.
- 3) Fill the tank half full with hot water 40° □50°C. Add detergent e.g. DIVER SEY – SU91 available in Italy or DIVER SEY – VK3L available in other countries) using a concentration of the product around between 5 □10%.
- 4) Plug in the unit and operate the machine for a few minutes ON WASH, Unplug it again.
- 5) Wash carefully using a sponge and **NON-ABRASIVE** materials.
- 6) Dismantle the turbine and clean thoroughly using the same solution used for the freezer tube. Re-assemble the parts and prepare the machine for production.
- 7) Rinse thoroughly using copious clean water minimum 20/30 LT.

SANITIZING

- 8) Before starting production the machine must be sanitized as follows:
Prepare a solution with acid (e.g. Percitric or Peracetic) adding **COLD** water (MAX. 25° C) so as to obtain a final concentration of 0.1 □0.3%. Keep the mixture in the machine for approx. 5 minutes making sure that all the surfaces which will come into contact with the finished product are treated with the solution. Drain and rinse carefully using copious amounts of water.



CAUTION! DO NOT USE HOT WATER WHEN PREPARING THE ACIDS INDICATED ABOVE.



**IMPORTANT: TO PREVENT ANY PROBLEMS OF CORROSION, DO NOT LEAVE THE SANITIZING
SOLUTION INSIDE THE MACHINE FOR PERIODS OF OVER 10 MINUTES.**



Dismantling the batch freezer dasher

**CUT OFF THE TENSION TO THE CONTROL CONSOLE
 PRESSING THE "START" KEY.(LIGHT OFF)**

Open front door (F) turning the handle (MF)
 anticlockwise and pull it towards you.



Extract the dasher (1), holding it by the spokes and
 pull it outwards.

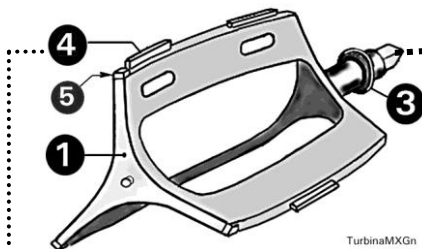
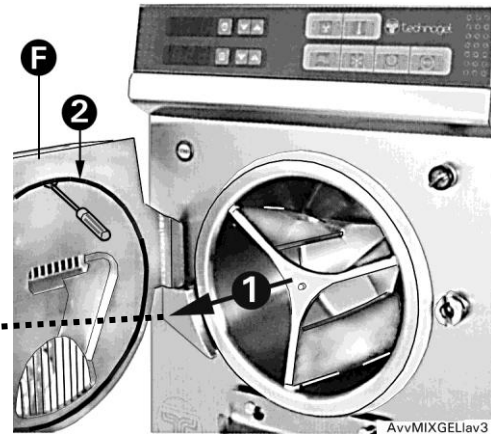

Dismantle the scraper blades (4) and the stop
 device (3) and wash thoroughly in the sink.

After drying carefully, re-assemble the stop
 device V shaped seal (3) greasing it slightly
 with vaseline together with the scraper blades
 (4). Take care to assemble correctly as shown
 in the drawing.

Re-assemble the dasher (1) in the machine
 pushing it firmly to the bottom and fitting the
 triangular piece in its seat with the help of the
 dasher spokes.

Dismantle the internal washer (2) of front door
 (F); using a screw driver, insert it in the seat
 in the flange and remove the washer. Wash it
 and re-assemble after greasing it slightly with
 vaseline.

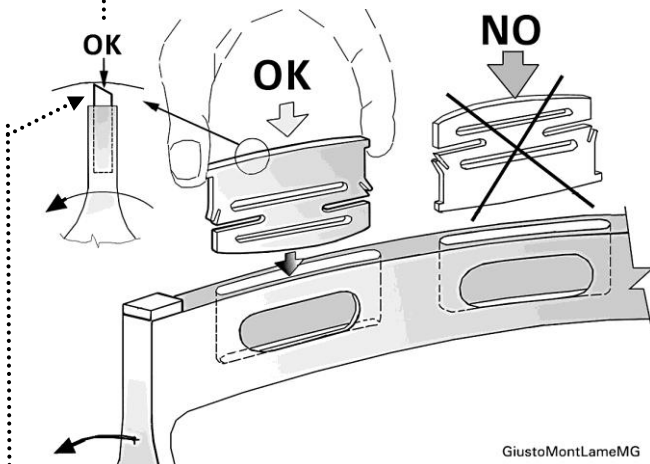

**PAY ATTENTION TO THE DIRECTION OF THE
 SCRAPING**



Cleaning the lid and control console

The blue film on the console must be cleaned using a sponge soaked in hot or cold water and liquid detergent. An abrasive soap powder could ruin the film, scratching it and removing the colour.

Never use acids or solvents of any kind whatsoever; they would damage the film.

The lid of the (B) in Plexiglas. should be washed with hot or cold water together with liquid.

Do not use metal or rigid plastic brushes or abrasive metal pads of the kind normally used in the kitchen.

In attempting to remove stubborn dirt, do not under any circumstances use blades or metal tools (knives – scissors – screwdrivers – etc.) as these could cut the film.

Soak and soften with hot water and remove with a sponge or soft cloth.



⇒ **Never** perform the following actions during washing

*With the front door open and after dismantling the dasher **never wash** using the water jet supplied with the machine or an external hose pipe jet.*

Any water sprayed in could get inside the machine through the hole (1), and flood all the equipment.

The only time a jet of water can be used for washing purposes is when the mixer turbine is assembled in the freezer tube.

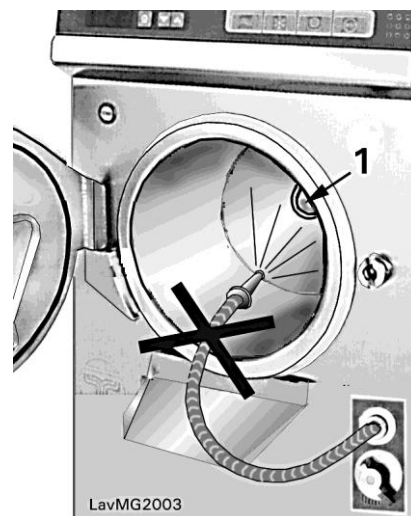

MAITENANCE

Maintenance: MANTEGEL 20

• For the operator

Each time the machine is washed, all accessible washers should be greased with vaseline to make assembly and operation easier.

Carry out maintenance every week by extracting the drawer (P) located on the left hand side of the machine to make sure there are no leakages from the turbine washer. If the drawer (P) is full of ice-cream, replace the turbine washer (3). For information on this please see below.



Periodically check the wear and tear on the scraper blades (4), see below, and when necessary replace them.

At the start of each new season, if necessary, replace all the washers. See below for the Order Code.

Pos.	N° pieces For dasher	Name of Component	Order Code	
3	1	MANTEGEL 20 dasher washer	GU-3903.0/10	
4	3	Scraper blade*	ME-11171,0/10	
5	3	Turbine centre block*	ME-11172.0	
-	-	MANTEGEL 20 washer kit	ME-0277	

* When the scraper blades are replaced, the dasher centre blocks must also be replaced.

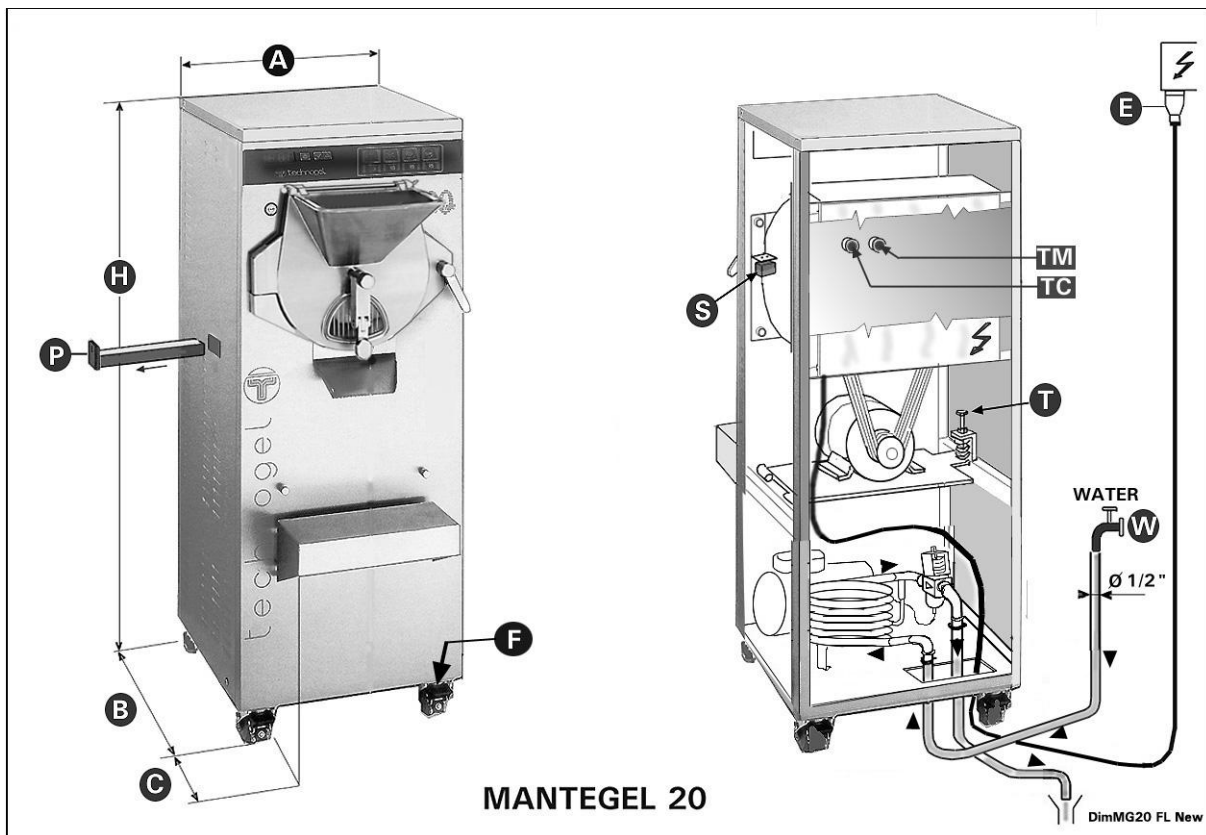

• For the Authorized Technician

After the first month's operation, check the tension on the turbine stirrer motor belts. To increase tension, adjust screw (T) as shown in the figure.

At the end of each season or at the start of the new one, carry out the following checks:

- check the refrigeration system is operating efficiently: quantity of refrigerating gas and cleaning of the Condenser
- check the state of wear and tear on the transmission belts and replace if necessary



Maintenance: MANTEGEL 30

• For the operator

Each time the machine is washed, all accessible washers should be greased with vaseline to make assembly and operation easier.

Carry out maintenance every week by extracting the drawer (P) located on the left hand side of the machine to make sure there are no leakages from the turbine washer. If the drawer (P) is full of ice-cream, replace the turbine washer (3). For information on this please see below.



Periodically check the wear and tear on the scraper blades (4), see below, and when necessary replace them.

At the start of each new season, if necessary, replace all the washers. See below for the Order Code.

Pos.	N° pieces For dasher	Name of Component	Order Code	
3	1	MANTEGEL 30 dasher washer	GU-3903.0/10	
4	3	Scraper blade*	ME-11171,0/10	
5	3	Turbine centre block*	ME-11172.0	
-	-	MANTEGEL 30 washer kit	ME-0277	
-	-			

* When the scraper blades are replaced, the dasher centre blocks must also be replaced.

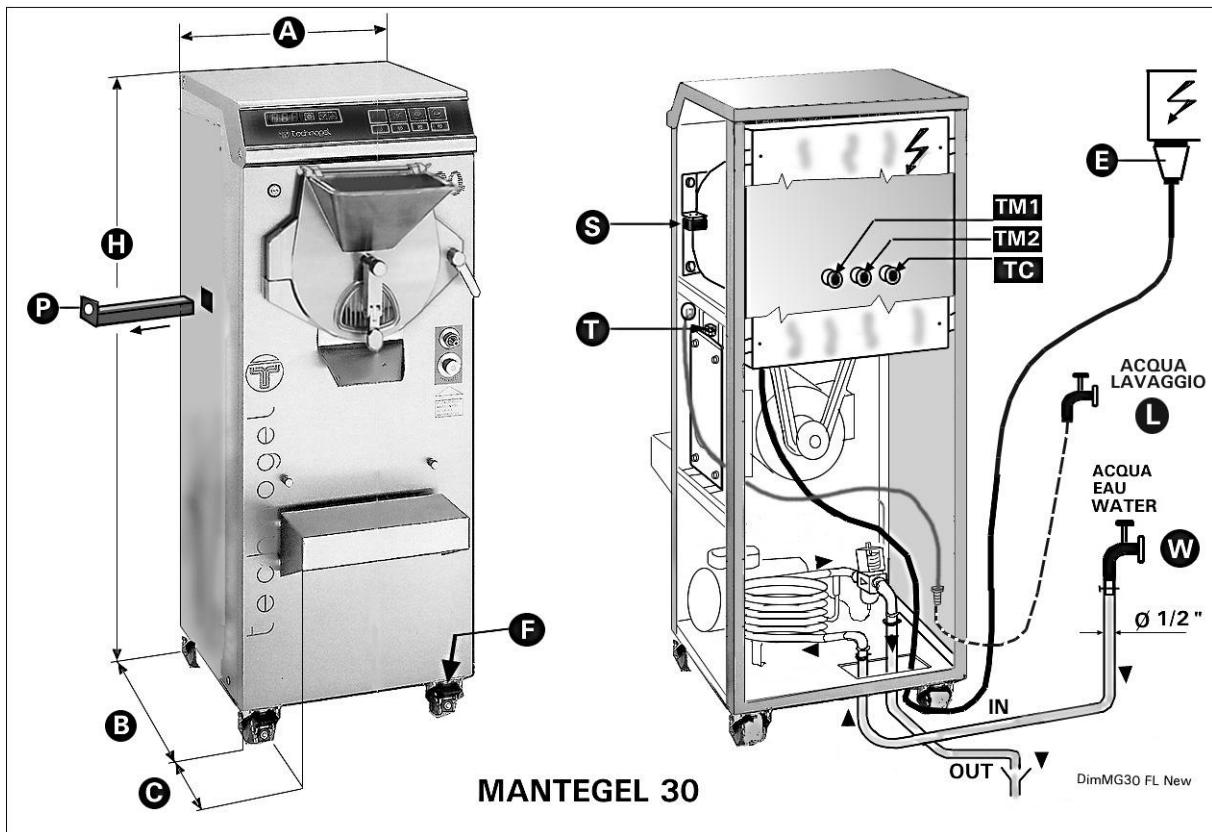

• For the Authorized Technician

After the first month's operation, check the tension on the turbine stirrer motor belts. To increase tension, adjust screw (T) as shown in the figure.

At the end of each season or at the start of the new one, carry out the following checks:

- check the refrigeration system is operating efficiently: quantity of refrigerating gas and cleaning of the Condenser
- check the state of wear and tear on the transmission belts and replace if necessary



Maintenance: MANTEGEL 50

• For the operator

Each time the machine is washed, all accessible washers should be greased with vaseline to make assembly and operation easier.

Carry out maintenance every week by extracting the drawer (P) located on the left hand side of the machine to make sure there are no leakages from the turbine washer. If the drawer (P) is full of ice-cream, replace the turbine washer (3). For information on this please see below.



Periodically check the wear and tear on the scraper blades (4), see below, and when necessary replace them.

At the start of each new season, if necessary, replace all the washers. See below for the Order Code.

Pos.	N° pieces For dasher	Name of Component	Order Code	
3	1	MANTEGEL 50 dasher washer	GU-3905.0	
4	6	Scraper blade*	ME-11171,0/10	
5	3	Dasher centre block*	ME-11172.0	
-	-	MANTEGEL 50 washer kit	ME1-0129	

* When the scraper blades are replaced, the dasher centre blocks must also be replaced.

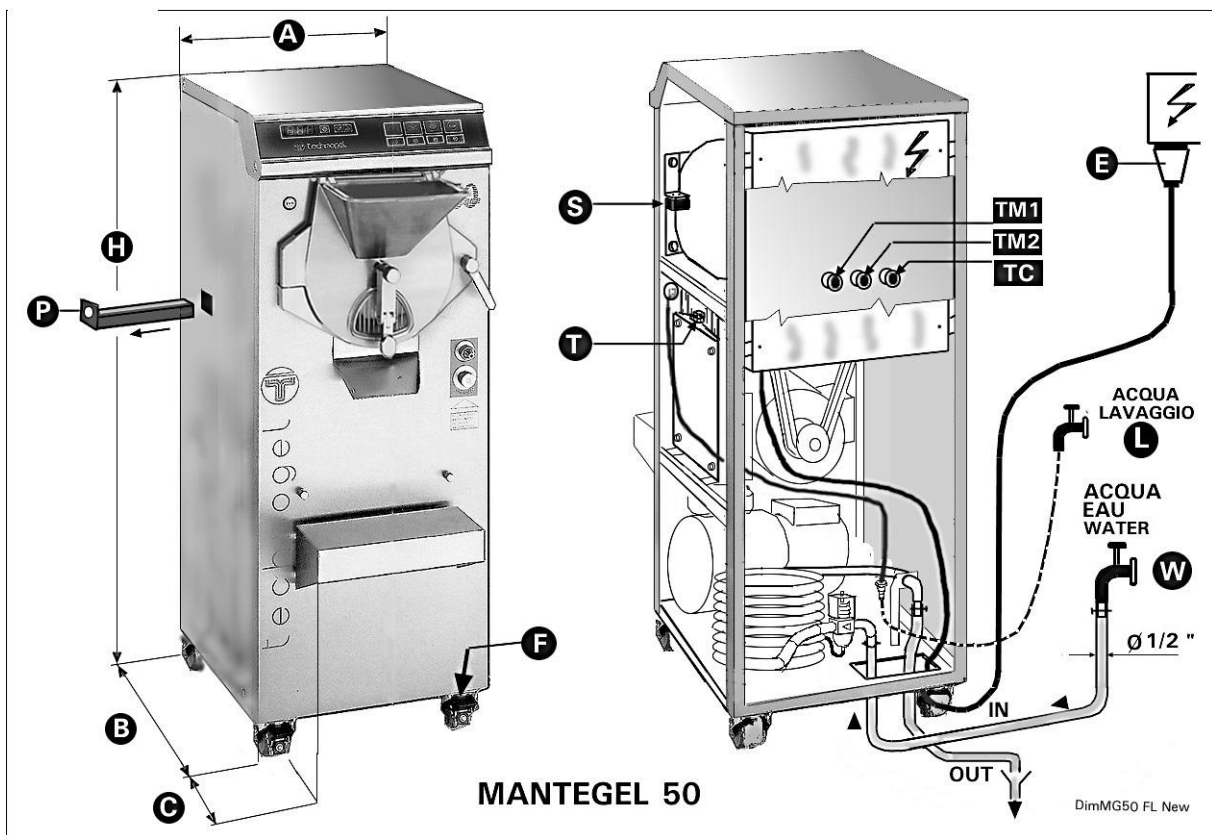

• For the Authorized Technician

After the first month's operation, check the tension on the turbine stirrer motor belts. To increase tension, adjust screw (T) as shown in the figure.

At the end of each season or at the start of the new one, carry out the following checks:

- check the refrigeration system is operating efficiently: quantity of refrigerating gas and cleaning of the Condenser
- check the state of wear and tear on the transmission belts and replace if necessary



Maintenance: MANTEGEL 70

• For the operator

Each time the machine is washed, all accessible washers should be greased with vaseline to make assembly and operation easier.

Carry out maintenance every week by extracting the drawer (P) located on the left hand side of the machine to make sure there are no leakages from the turbine washer. If the drawer (P) is full of ice-cream, replace the turbine washer (3). For information on this please see below.



Periodically check the wear and tear on the scraper blades (4), see below, and when necessary replace them.

At the start of each new season, if necessary, replace all the washers. See below for the Order Code.

Pos.	N° pieces For dasher	Name of Component	Order Code	
3	1	MANTEGEL 70 dasher washer	GU-3906.0	
4	8	Scraper blade*	ME-11171,0/10	
5	3	Dasher centre block*	ME-11172.0	
-	-	MANTEGEL 70 washer kit	ME-0352	
-	-			

* When the scraper blades are replaced, the dasher centre blocks must also be replaced.

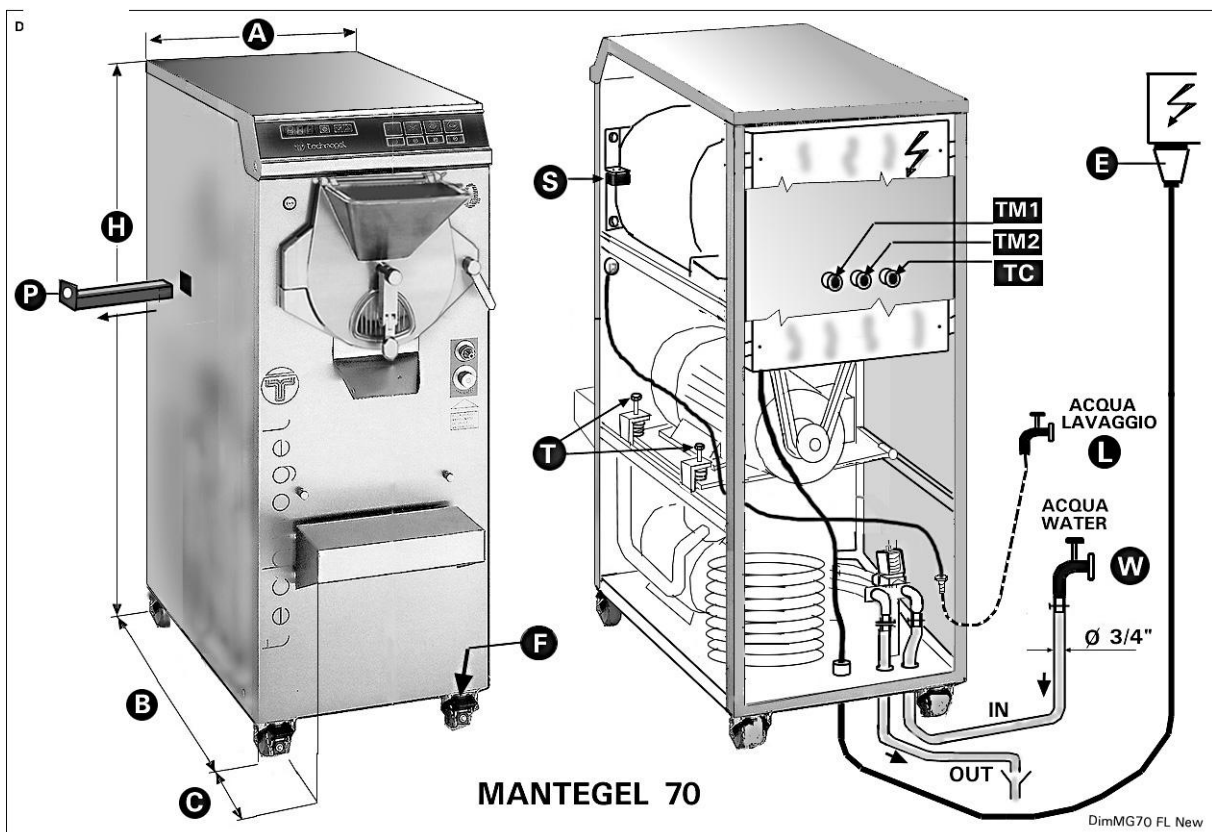

• For the Authorized Technician

After the first month' s operation, check the tension on the turbine stirrer motor belts. To increase tension, adjust screw (T) as shown in the figure.

At the end of each season or at the start of the new one, carry out the following checks:

- check the refrigeration system is operating efficiently: quantity of refrigerating gas and cleaning of the Condenser
- check the state of wear and tear on the transmission belts and replace if necessary



Noise level

The noise level when the machine is working, at 1 metre from the machine, is less than 70 dB (A).

.....

⇒ ECOLOGICAL WARNING

"This machine contains substances that damage the stratospheric ozone; when it is no longer in use it must be handed over to the appropriate collection centres: please ask the local authorities in your town for information about the refuse collection service."

⇒ Attention: risk of machine damage

If, during the winter, the laboratory is not used, make sure that the room where the machines are stored is kept at a temperature above 0°C.

As this machine is cooled by water, the refrigerating unit could be broken by ice to great financial cost.

To drain the water in the condensation plant, call an **AUTHORIZED TECHNICAL SERVICE**.

TROUBLE-SHOOTING

WARNING DANGER!!!

Technical work carried out on the inside of the machine by unauthorized persons may put the safety of the same at risk.

We therefore recommend that you always call an **AUTHORIZED TECHNICIAN** in the event of machine breakdown.

TECHNOGEL CANNOT BE HELD LIABLE FOR ANY DAMAGE ARISING FROM TECHNICAL WORK CARRIED OUT BY UNAUTHORIZED PERSONS

FURTHERMORE, TECHNOGEL CANNOT BE HELD LIABLE FOR ANY DAMAGE ARISING FROM NON-ORIGINAL, AND SO NOT RECOGNIZED, SPARE PARTS FITTEN ON ONE OF ITS MACHINES.







.....

The following pages provide **RESERVED INFORMATION FOR TECHNICIANS** with technical sheets for each machine.



Troubleshooting

The user can carry out operations on the machine without any risk of danger only when the user symbol is indicated

In all other cases operations must be carried out exclusively by Authorized Technicians.

MALFUNCTION	CAUSE	REMEDY	
Refrigerator compressor stops.	The thermal overload switch has tripped.	Reset by pressing the pushbutton (pos. TC page 29)	
	Maximum pressure switch has tripped.	Check that there is sufficient cooling water.	
	Maximum pressure switch not calibrated or defective.	Check and adjust.	
"Ice-cream ready" buzzer rings repeatedly on start-up.	Electronic gear-case has been calibrated too low.	Increase the value stored in gear-case. (page 14)	
	Faulty amperometric gear-case	Check and/or replace.	
Freezing time too long.	Scraping blades are worn and so ice-cream crust forms limiting thermal transfer.	Replace all scraping blades and centring blocks (if blocks are not replaced, the new blades will not function properly)	
	Insufficient refrigerating gas. Thermostat valve is too tightly closed so evaporation temperature very low, even at start of cycle.	Check and fill up if necessary. See type of Gas and quantity on page 5 or on the machine plate behind the machine. Open the thermostat valve or replace it if blocked.	
Dasher motor stops during ice-cream removal.	Ice-cream is too thick, triggering overload cutout switch.	Reset using the triggering reset button on the back (page 29 pos. TM1) and check the set value on the amperometric gear-case: probably too high.	
The dasher motor stops during the ice-cream evacuation stage	The machine has passed from the freezing stage to evacuation passing via STOP and it waits a few seconds on STOP.	Pass immediately from freezing to evacuation without pressing STOP. Reset with the reset button (page 29, pos. TM2).	

Troubleshooting

MALFUNCTION	CAUSE	REMEDY	
Dasher stops during freezing phase even if motor is turning.	Belts that transmit motion to the turbine are too loose. The belts are worn and no longer transmit movement to the turbine.	Reset the correct draught by adjusting the screws at pos. T . Replace all the belts. Never replace just one belt. The whole set must be changed.	
The machine stops during work cycle and the control console switches off.	The front door safety switch has broken.	Replace the switch at pos. S .	

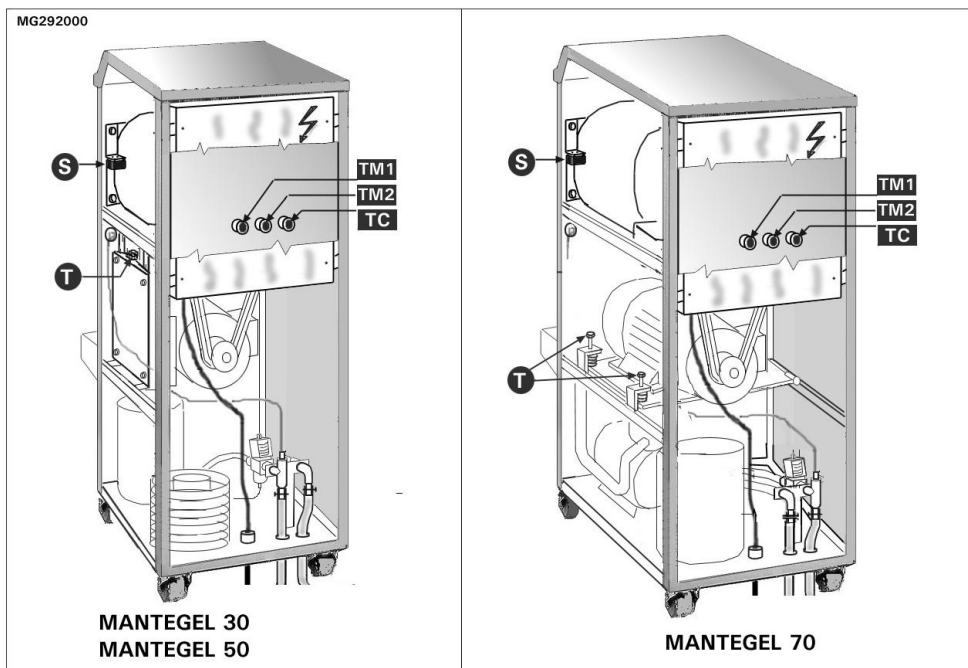
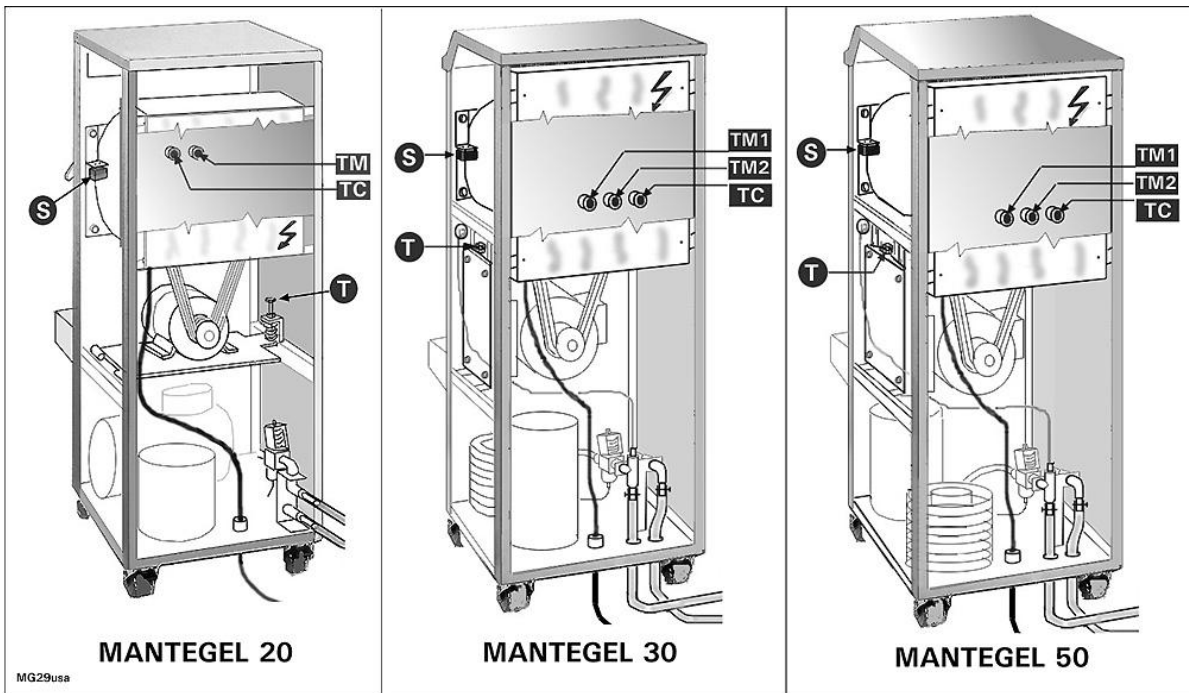

TECHNICAL CHARACTERISTICS WITH DIAGRAMS

Section reserved for Authorized Service Technician

MANTEGEL 20 WATER - technical specifications

Refrigerator compressor	Semi-airtight HP 1,8 (KW 1,35)
Refrigerating gas	Freon R404A (quantity 3,5 Kg.)
Mixer motor	900 r.p.m. KW 1,3
Condensation	Water (minimum pressure 1 Bar)

Overload cutout calibration	V.200 50/60HZ	V.220 50HZ	V.220 60HZ	V.400 50HZ	V.380 60HZ	V.415 50HZ
Compressor A.		6	9,5	4	4	4
Dasher motor A.		6	9	4	4	4

Electrical fuse	V.200 e V.220	V.380 e V.415
Line protection	n°3 d. 10 x 38 16A. AM type	n°3 d. 10 x 38 16A. AM type
Compressor resist. protect.	n°1 d. 5 x 20 0,5A. rapid type	n°1 d. 5 x 20 0,5A. rapid type
F2 primary transformer	n°2 d. 5 x 20 6,3A. delayed type	n°2 d. 5 x 20 6,3A. delayed type
F3 secondary transformer	n°2 d. 5 x 20 6,3A. delayed type	n°2 d. 5 x 20 6,3A. delayed type
Motor blocking protection	n° 2 d. 10 x 38 6A. delayed type	n° 2 d. 10 x 38 4A. delayed type

Fixed calibration high pressure switch	Intervention pressure values (+ /-0,5 Bar)
Coutout pressure	20,7 Bar = 300 Psi
Connect pressure	13,8 Bar = 200 Psi
Differential	6,9 Bar = 100 Psi

REFRIGERATION PLANT WORKING PRESSURES AND TEMPERATURES

Condensation	Cycle startup	End of cycle (ice-cream ready)
+ 35° C = 12,5 Bar 95° F = 225 Psi	-20° C = 2 Bar -5° F = 23,5 Psi	-33° C = 0,8 Bar -27,4° F = 12 Psi

The machine is supplied with the above default values and settings.

TECHNOGEL CANNOT BE HELD LIABLE FOR ANY DAMAGE TO PROPERTY OR INJURY TO PERSONS ARISING FROM CHANGES MADE TO THE DEFAULT SETTINGS OR FROM THE USE OF CUTOUT FUSES OR FUSES WITH INCORRECT CHARACTERISTICS OR IN ANY EVENT FUSES DIFFERING FROM THOSE PRESCRIBED.

Refrigerator Plant : MANTEGEL 20 COOLING WATER

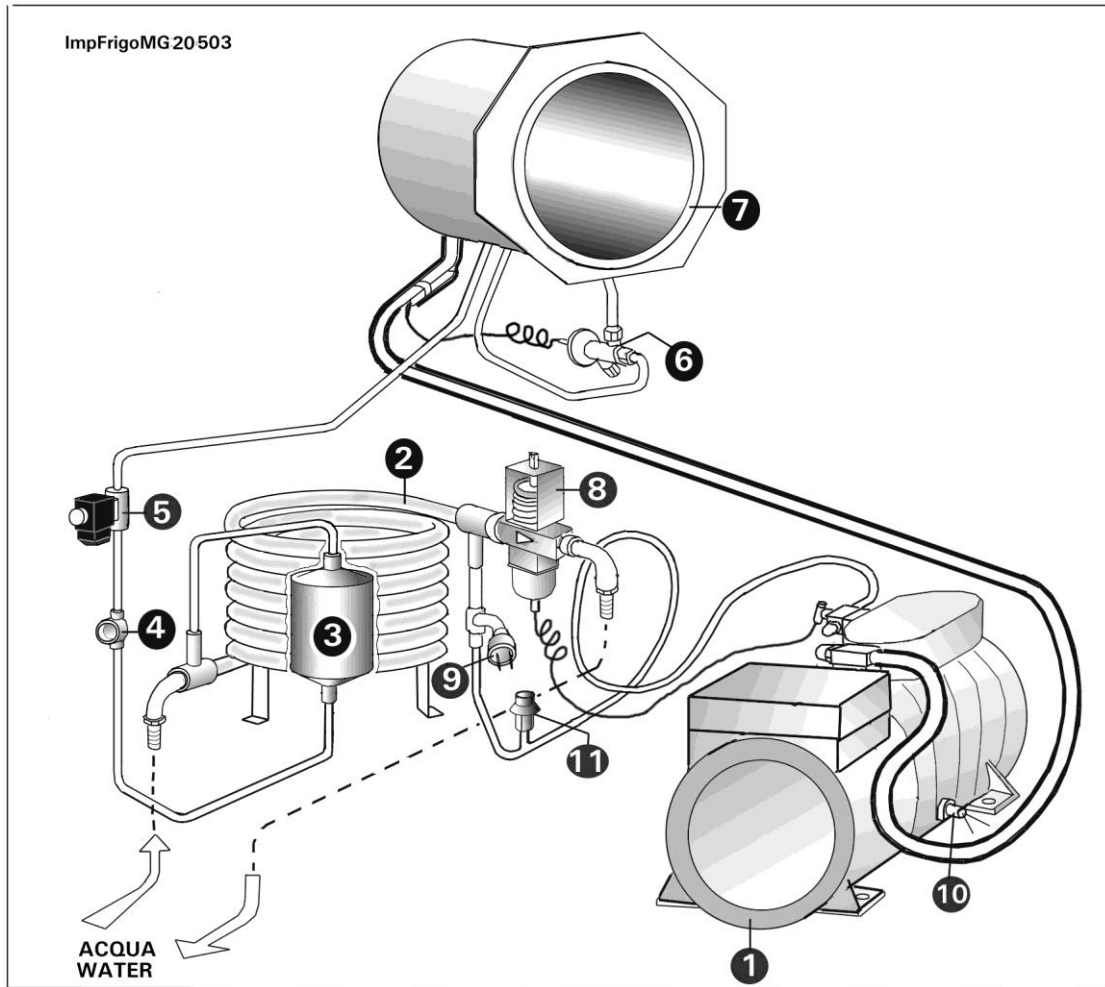

Pos.	Component Name	Code
1	Compressor REFRIGERATOR: - 220V-240/380-415 50HZ - 220/240V 60HZ	CP-17846.6
2	Condensatore in rame a tubi concentrici	CD-8398.6/20
3	Filtro deidratore	CD-14764.6
4	Spia del liquido e verifica umidità	CD-16612.6
5	Valvola solenoide senza bobina - solo Bobina elettrica 24V 50/60HZ	FR6-0319 VV-5616.6
6	Valvola termostatica di espansione	VT-15424.4
7	Tubo congelatore evaporatore isolato	M2-4957.3IS
8	Valvola pressostatica dell' acqua	MC-0039
9	Pressostato di alta pressione a taratura fissa	TR6251.6
10	Resistenza elettrica per carter compressore frigorifero	ME1-0131
11	Valvola di sicurezza impianto frigorifero	TR-18096.6

For the order of the spare parts of the refrigerator unit, as well as the code please always mention :

- 1) - Machine Type
- 2) - Serial Number
- 3) - Voltage
- 4) - Hertz

MANTEGEL 20 AIR - technical specifications

Refrigerator compressor	Semi-airtight HP 1,8 (KW 1,3)
Refrigerating gas	Freon R404A (quantity 3,5 Kg.)
Condenser Ventilators	N° 2 – 220V monophas kW 0,135 cad.
Condensation	AIR

Overload cutout calibration	V.200 50/60HZ	V.220 50HZ	V.220 60HZ	V.400 50HZ	V.380 60HZ	V.415 50HZ
Compressor A.		6	9,5	4		
Dasher motor A.		6	9	4		

Electrical fuse	V.200 e V.220	V.380 e V.415
Line protection	n°3 d. 10 x 38 16A. AM type	n°3 d. 10 x 38 16A. AM type
Compressor resist. protect.	n°1 d. 5 x 20 0,5A. rapid type	n°1 d. 5 x 20 0,5A. rapid type
F2 primary transformer	n°2 d. 5 x 20 6,3A. delayed type	n°2 d. 5 x 20 6,3A. delayed type
F3 secondary transformer	n°2 d. 5 x 20 6,3A. delayed type	n°2 d. 5 x 20 6,3A. delayed type
Motor blocking protection	n° 2 d. 10 x 38 6A. delayed type	n° 2 d. 10 x 38 4A. delayed type

Fixed calibration high pressure switch	Intervention pressure values (+ /-0,5 Bar)
Coutout pressure	20,7 Bar = 300 Psi
Connect pressure	13,8 Bar = 200 Psi
Differential	6,9 Bar = 100 Psi

REFRIGERATION PLANT WORKING PRESSURES AND TEMPERATURES

Condensation	Cycle startup	End of cycle (ice-cream ready)
+ 35° C = 12,5 Bar 95° F = 225 Psi	-20° C = 2 Bar -5° F = 23,5 Psi	-33° C = 0,8 Bar -27,4° F = 12 Psi

The machine is supplied with the above default values and settings.

TECHNOGEL CANNOT BE HELD LIABLE FOR ANY DAMAGE TO PROPERTY OR INJURY TO PERSONS ARISING FROM CHANGES MADE TO THE DEFAULT SETTINGS OR FROM THE USE OF CUTOUT FUSES OR FUSES WITH INCORRECT CHARACTERISTICS OR IN ANY EVENT FUSES DIFFERING FROM THOSE PRESCRIBED.

➤ Refrigerator Plant : MANTEGEL 20 COOLING AIR

Mantegel 20 Condensation Air

MANTEGEL 20 - CONDENSAZIONE ARIA

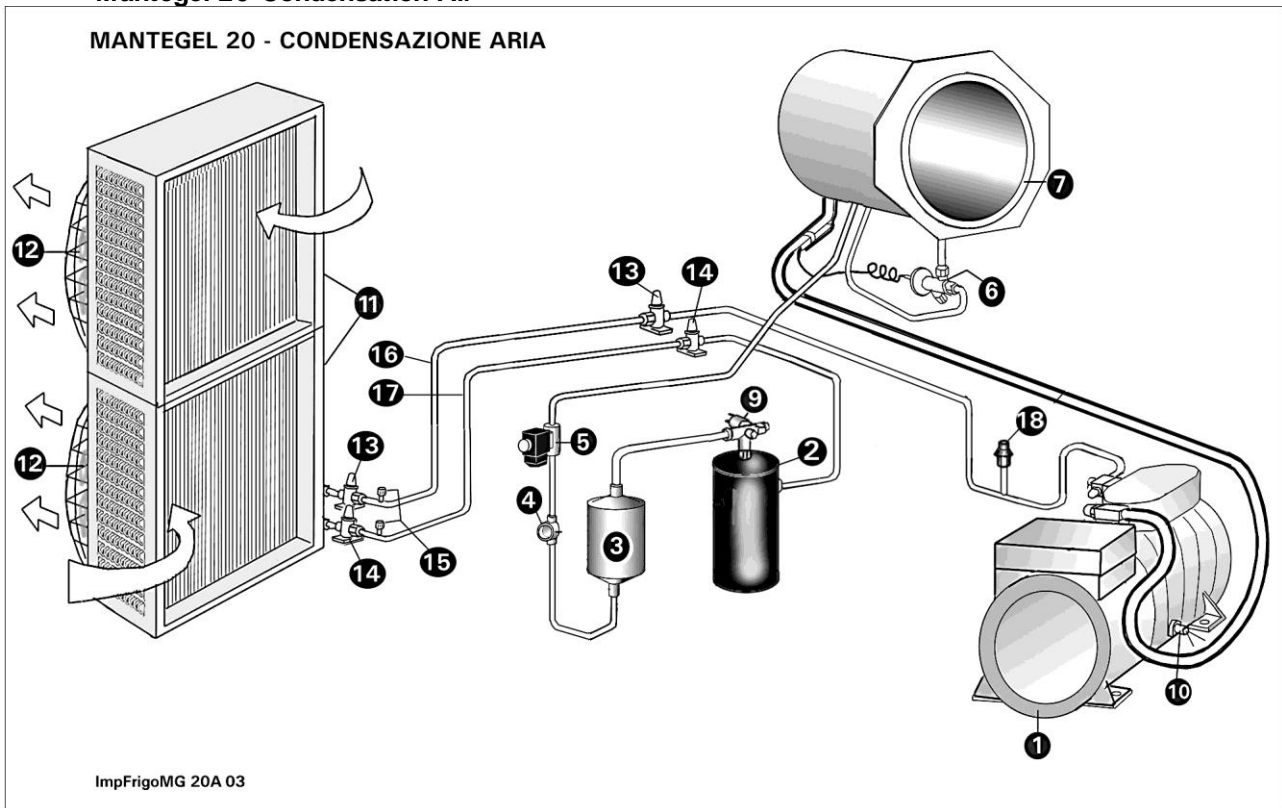

Pos.	Component Name	Code
1	Compressore frigorifero semiermetico - 220-240V/380-415V 50HZ - 220-240V 60HZ	CP-17846.6
2	Ricevitore di liquido	
3	Filtro deidratatore	CD-14764.6
4	Spia del liquido e segnalatore di umidità	CD-16612.6
5	Valvola solenoide senza bobina - solo Bobina elettrica 24V 50/60HZ	VV-5615.6 VV-5616.6
6	Valvola termostatica di espansione	VT-15424.4
7	Tubo congelatore evaporatore isolato	M2-4957.3IS
9	Pressostato alta pressione a taratura fissa	TR-19055.6
10	Resistenza elettrica carter compressore frigorifero	FR3-0004
11	Condensatore ad aria	CD-9124.6/10
12	Ventilatori condensatore	
18	Valvola di sicurezza del circuito frigorifero	TR-18096.6

For montage condenser air isolate:

13	Rubinetti per tubo di mandata	
14	Rubinetti per tubo di ritorno	
15	Valvole per effettuare il vuoto alle tubazioni di mandata e ritorno	
16	Tubazione di mandata (in rame o flessibile) da predisporre in opera	
17	Tubazione di ritorno (in rame o flessibile) da predisporre in opera	

For the order of the spare parts of the refrigerator unit, as well as the code please always mention :

1) - Machine Type 2) - Serial Number 3) - Voltage 4) - Hertz

MANTEGEL 30 WATER - technical specifications

Refrigerator compressor	Semi-airtight HP 2 (KW 1,5)
Refrigerating gas	Freon R404A (quantity 1,2 Kg.)
Mixer motor	750/1500 r.p.m. KW 1,3/2,6
Condensation	Water (minimum pressure 1,5 Bar)

Overload cutout calibration	V.200 50/60HZ	V.220 50HZ	V.220 60HZ	V.400 50HZ	V.380 60HZ	V.415 50HZ
Compressor A.		9,5	9,5	5,5		
Dasher motor:						
- low velocity A.		8,5	9	5,5		
- high velocity A.		13,5	13	9		

Electrical fuse	V.200 e V.220	V.380 e V.415
Line protection	n°3 d. 10 x 38 25A. AM type	n°3 d. 10 x 38 20A. AM type
Compressor resist. protect.	n°1 d. 5 x 20 0,5A. rapid type	n°1 d. 5 x 20 0,5A. rapid type
F2 primary transformer	n°2 d. 5 x 20 2A. rapid type	n°2 d. 5 x 20 6,3A. delayed type
F3 secondary transformer	n°2 d. 5 x 20 6,3A. delayed type	n°2 d. 5 x 20 6,3A. delayed type
Motor blocking protection	n°2 d. 10 x 38 16A. delayed type	n°2 d. 10 x 38 6A. delayed type

Fixed calibration high pressure switch	Intervention pressure values (+ /-0,5 Bar)
Coutout pressure	20,7 Bar = 300 Psi
Connect pressure	13,8 Bar = 200 Psi
Differential	6,9 Bar = 100 Psi

Safety Valve	(11)	Intervention Bar 28 (+ - 0,5 Bar)
--------------	------	-----------------------------------

REFRIGERATION PLANT WORKING PRESSURES AND TEMPERATURES

Condensation	Cycle startup	End of cycle (ice-cream ready)
+ 35° C = 12,5 Bar 95° F = 225 Psi	-20° C = 2 Bar -5° F = 23,5 Psi	-33° C = 0,8 Bar -27,4° F = 12 Psi

The machine is supplied with the above default values and settings.

TECHNOGEL CANNOT BE HELD LIABLE FOR ANY DAMAGE TO PROPERTY OR INJURY TO PERSONS ARISING FROM CHANGES MADE TO THE DEFAULT SETTINGS OR FROM THE USE OF CUTOUT FUSES OR FUSES WITH INCORRECT CHARACTERISTICS OR IN ANY EVENT FUSES DIFFERING FROM THOSE PRESCRIBED.

Refrigerator Plant : MANTEGEL 30 COOLING WATER

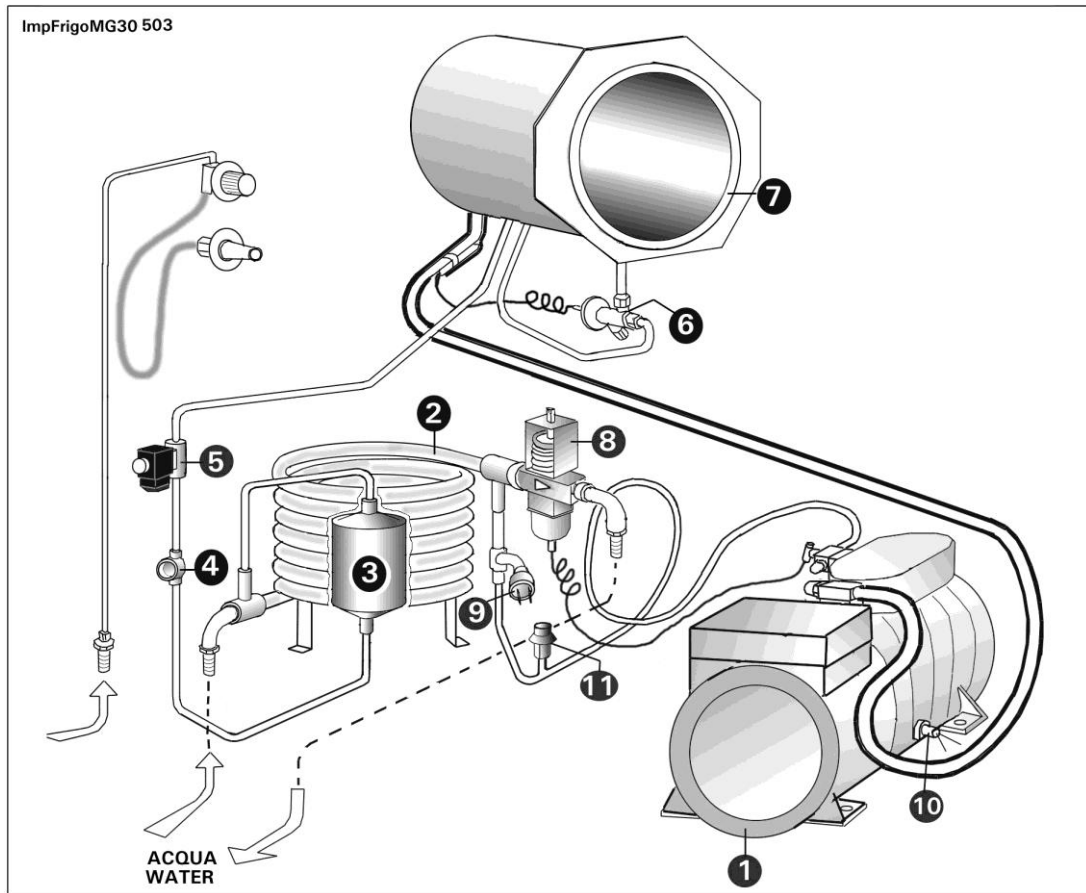

Pos.	Component Name	Code
1	Compressore frigorifero semiermetico - 220-240V/380-415V 50HZ	CP-18890.4
2	Condensatore in rame a tubi concentrici	CD-8398.6/20
3	Filtro deidratatore	CD-14764.6
4	Spia del liquido e verifica umidità	CD-16612.6
5	Valvola solenoide senza Bobina - solo Bobina elettrica 24V 50-60HZ	FR6-0319 VV-5616.6
6	Valvola termostatica di espansione	VT-15424.4
7	Tubo congelatore evaporatore isolato	ME-4962.3IS
8	Valvola pressostatica dell' acqua	VT-17909.6
9	Pressostato di alta pressione a taratura fissa	TR-19055.6
10	Resistenza elettrica per carter compressore frigorifero	ME1-0131
11	Valvola di sicurezza impianto frigorifero	TR-18096.6

For the order of the spare parts of the refrigerator unit, as well as the code please always mention :

- 1) - Machine Type
- 2) - Serial Number
- 3) - Voltage
- 4) - Hertz

MANTEGEL 30 AIR - technical specifications

Refrigerator compressor	Semi-airtight HP 2 (KW 1,5)
Refrigerating gas	Freon R404A (quantity 1,2 Kg.)
Condenser Ventilators	N° 2 – 220V monophas kW 0,135 cad.
Condensation	AIR

Overload cutout calibration	V.200 50/60HZ	V.220 50HZ	V.220 60HZ	V.400 50HZ	V.380 60HZ	V.415 50HZ
Compressor A.		9,5	9,5	5,5		
Dasher motor:						
- low velocity A.		8,5	9	5,5		
- high velocity A.		13,5	13	9		

Electrical fuse	V.200 e V.220	V.380 e V.415
Line protection	n°3 d. 10 x 38 25A. AM type	n°3 d. 10 x 38 20A. AM type
Compressor resist. protect.	n°1 d. 5 x 20 0,5A. rapid type	n°1 d. 5 x 20 0,5A. rapid type
F2 primary transformer	n°2 d. 5 x 20 2A. rapid type	n°2 d. 5 x 20 6,3A. delayed type
F3 secondary transformer	n°2 d. 5 x 20 6,3A. delayed type	n°2 d. 5 x 20 6,3A. delayed type
Motor blocking protection	n° 2 d. 10 x 38 16A. delayed type	n° 2 d. 10 x 38 6A. delayed type

Fixed calibration high pressure switch	Intervention pressure values (+ /-0,5 Bar)
Coutout pressure	20,7 Bar = 300 Psi
Connect pressure	13,8 Bar = 200 Psi
Differential	6,9 Bar = 100 Psi

Safety Valve	(11)	Intervention Bar 28 (+ - 0,5 Bar)
--------------	------	-----------------------------------

REFRIGERATION PLANT WORKING PRESSURES AND TEMPERATURES

Condensation	Cycle startup	End of cycle (ice-cream ready)
+ 35° C = 12,5 Bar 95° F = 225 Psi	-20° C = 2 Bar -5° F = 23,5 Psi	-33° C = 0,8 Bar -27,4° F = 12 Psi

The machine is supplied with the above default values and settings.

TECHNOGEL CANNOT BE HELD LIABLE FOR ANY DAMAGE TO PROPERTY OR INJURY TO PERSONS ARISING FROM CHANGES MADE TO THE DEFAULT SETTINGS OR FROM THE USE OF CUTOUT FUSES OR FUSES WITH INCORRECT CHARACTERISTICS OR IN ANY EVENT FUSES DIFFERING FROM THOSE PRESCRIBED.

Refrigerator Plant : MANTEGEL 30 COOLING AIR

Mantegel 30 Condensation Air

MANTEGEL 30 - CONDENSAZIONE ARIA

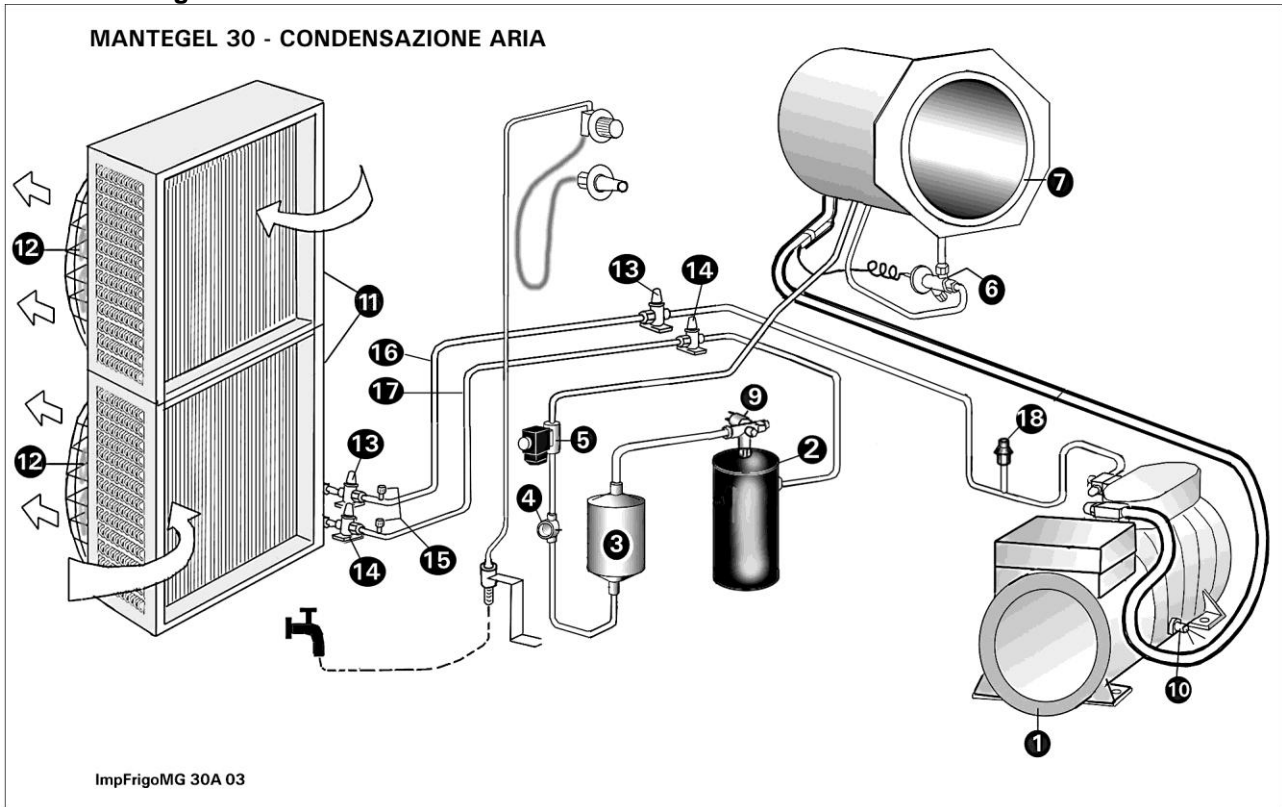

Pos.	Component Name	Code
1	Compressore frigorifero semiermetico - 220-240V/380-415V 50HZ - 220-240V 60HZ - 200V 50-60HZ	CP-6576.6/10 MC-0108/6 MC0108/2B
2	Ricevitore di liquido	
3	Filtro deidratore	CD-5623.6
4	Spia del liquido e segnalatore di umidità	M2-0049
5	Valvola solenoide senza Bobina elettrica - solo Bobina elettrica 24V 50-60HZ	VV-5614.6 VV-5616.6
6	Valvola termostatica di espansione	VT-15424.4
7	Tubo congelatore evaporatore isolato	ME-4962.3IS
9	Pressostato alta pressione a taratura fissa	TR-19055.6
10	Resistenza elettrica carter compressore frigorifero	ME-0131
11	Condensatore ad aria	CD-9124.6/10
12	Ventilatori condensatore	
18	Valvola di sicurezza del circuito frigorifero	TR-18096.6

For montage condenser air isolate:

13	Rubinetti per tubo di mandata	
14	Rubinetti per tubo di ritorno	
15	Valvole per effettuare il vuoto alle tubazioni di mandata e ritorno	
16	Tubazione di mandata (in rame o flessibile) da predisporre in opera	
17	Tubazione di ritorno (in rame o flessibile) da predisporre in opera	

For the order of the spare parts of the refrigerator unit, as well as the code please always mention :

- 1) - Machine Type
- 2) - Serial Number
- 3) - Voltage
- 4) - Hertz

MANTEGEL 30 AIR WATER - technical specifications

Refrigerator compressor	Semi-airtight HP 2 (KW 1,5)
Refrigerating gas	Freon R404A (quantity 1,2 Kg.)
Mixer motor	750/1500 r.p.m. KW 1,3/2,6
Condenser Ventilators	N° 2 – 220V mono phase kW 0,135 cad.
Condensation	AIR Water (minimum pressure 1,5 Bar)

Overload cutout calibration		V.200 50/60HZ	V.220 50HZ	V.220 60HZ	V.400 50HZ	V.380 60HZ	V.415 50HZ
Compressor	A.		9,5	9,5	5,5		
Dasher motor:							
- low velocity	A.		8,5	9	5,5		
- high velocity	A.		13,5	13	9		

Electrical fuse	V.200 e V.220	V.380 e V.415
Line protection	n°3 d. 10 x 38 25A. AM type	n°3 d. 10 x 38 20A. AM type
Compressor resist. protect.	n°1 d. 5 x 20 0,5A. rapid type	n°1 d. 5 x 20 0,5A. rapid type
F2 primary transformer	n°2 d. 5 x 20 2A. rapid type	n°2 d. 5 x 20 6,3A. delayed type
F3 secondary transformer	n°2 d. 5 x 20 6,3A. delayed type	n°2 d. 5 x 20 6,3A. delayed type
Motor blocking protection	n°2 d. 10 x 38 16A. delayed type	n°2 d. 10 x 38 6A. delayed type

Fixed calibration high pressure switch	Intervention pressure values (+ /-0,5 Bar)
Coutout pressure	20,7 Bar = 300 Psi
Connect pressure	13,8 Bar = 200 Psi
Differential	6,9 Bar = 100 Psi

Safety Valve	(11)	Intervention Bar 28 (+ - 0,5 Bar)
--------------	------	-----------------------------------

REFRIGERATION PLANT WORKING PRESSURES AND TEMPERATURES

Condensation	Cycle startup	End of cycle (ice-cream ready)
+ 35° C = 12,5 Bar 95° F = 225 Psi	-20° C = 2 Bar -5° F = 23,5 Psi	-33° C = 0,8 Bar -27,4° F = 12 Psi

The machine is supplied with the above default values and settings.

TECHNOGEL CANNOT BE HELD LIABLE FOR ANY DAMAGE TO PROPERTY OR INJURY TO PERSONS ARISING FROM CHANGES MADE TO THE DEFAULT SETTINGS OR FROM THE USE OF CUTOUT FUSES OR FUSES WITH INCORRECT CHARACTERISTICS OR IN ANY EVENT FUSES DIFFERING FROM THOSE PRESCRIBED.

Refrigerator Plant : MANTEGEL 30 COOLING AIR/WATER

Mantegel 20 – Mantegel 30 - Condensation Air / Water

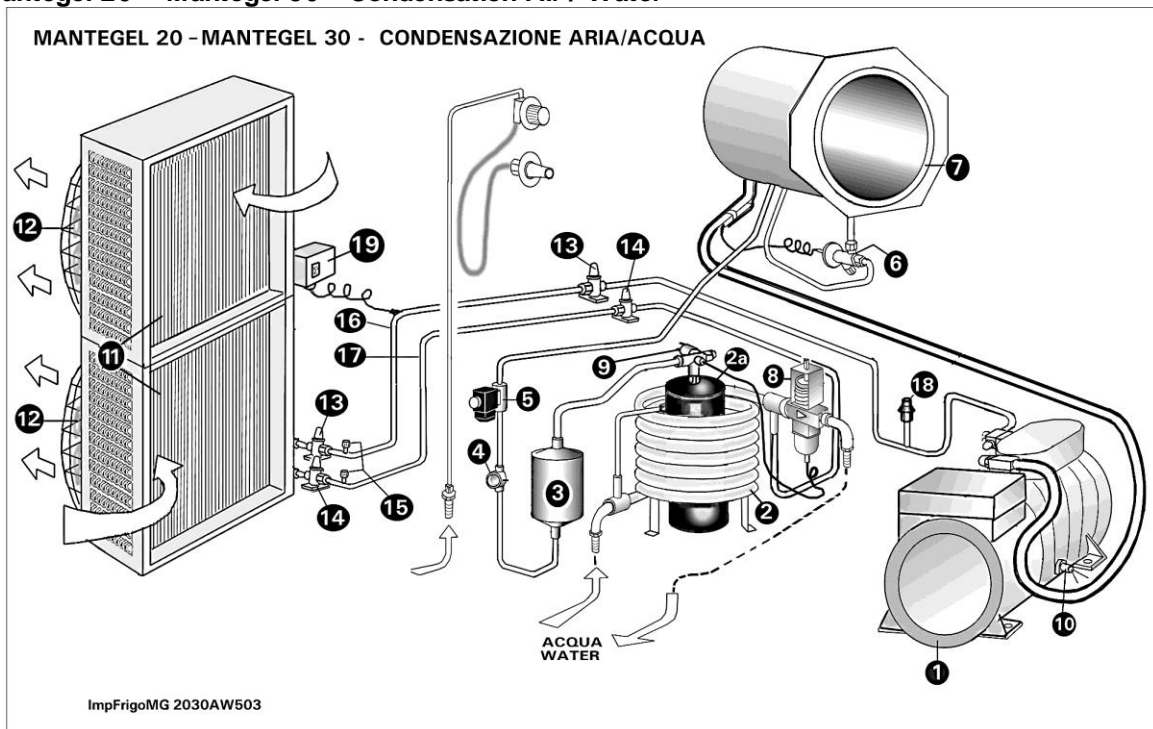

Pos.	Component Name	Code
1	Compressore frigorifero semiermetico - 220-240V/380-415V 50HZ - 220-240V 60HZ - 200V 50-60HZ	CP-6576.6/20 MC-0108/6 MC-0108/2B
2	Condensatore ad acqua a tubi concentrici	CD-8398.6/20
2a	Ricevitore di liquido	
3	Filtro deidratore	CD-5623.6
4	Spia del liquido e segnalatore di umidità	M2-0049
5	Valvola solenoide senza Bobina elettrica - solo Bobina elettrica	VV-5614.6 VV-5616.6
6	Valvola termostatica di espansione	VT-15424.4
7	Tubo congelatore evaporatore isolato	ME-4962.3IS
8	Valvola pressostatica dell' acqua	MC-0039
9	Pressostato alta pressione a taratura fissa	TR-19055.6
10	Resistenza elettrica carter compressore frigorifero	ME1-0131
11	Condensatore ad aria	CD-9124.6/10
12	Ventilatori condensatore	
18	Valvola di sicurezza del circuito frigorifero	TR-18096.6
19	Pressostato intervento ventilatori condensatore ad aria	

For montage condenser air isolate:

13	Rubinetti per tubo di mandata	
14	Rubinetti per tubo di ritorno	
15	Valvole per effettuare il vuoto alle tubazioni di mandata e ritorno	
16	Tubazione di mandata (in rame o flessibile) da predisporre in opera	
17	Tubazione di ritorno (in rame o flessibile) da predisporre in opera	

For the order of the spare parts of the refrigerator unit, as well as the code please always mention :

- 1) - Machine Type
- 2) - Serial Number
- 3) - Voltage
- 4) - Hertz

MANTEGEL 50 WATER- technical specifications

Refrigerator compressor	Semi-airtight HP 3 (KW 2,2)
Refrigerating gas	Freon R404A (quantity 1,2 Kg.)
Mixer motor	750/1500 r.p.m. KW 2,6/4,8
Condensation	Water (minimum pressure 1,5 Bar)

Overload cutout calibration	V.200 50/60HZ	V.220 50HZ	V.220 60HZ	V.380 50HZ	V.380 60HZ	V.415 50HZ
Compressor A.		13	13	7,5		
Dasher motor:						
- low velocity A.		11	11	9		
- high velocity A.		19	19	13,5		

Electrical fuse	V.200 e V.220	V.380 e V.415
Line protection	n°3 d. 10 x 38 32A. AM type	n°3 d. 10 x 38 25A. AM type
Compressor resist. protect.	n°1 d. 5 x 20 0,5A. rapid type	n°1 d. 5 x 20 0,5A. rapid type
F2 primary transformer	n°2 d. 5 x 20 2A. rapid type	n°2 d. 5 x 20 6,3A. delayed type
F3 secondary transformer	n°2 d. 5 x 20 6,3A. delayed type	n°2 d. 5 x 20 6,3A. delayed type
Motor blocking protection	n°2 d. 10 x 38 16A. delayed type	n°2 d. 10 x 38 6A. delayed type

Fixed calibration high pressure switch	Intervention pressure values (+ /-0,5 Bar)
Coutout pressure	20,7 Bar = 300 Psi
Connect pressure	13,8 Bar = 200 Psi
Differential	6,9 Bar = 100 Psi

Safety Valve	(11)	Intervention Bar 28 (+ - 0,5 Bar)
--------------	------	-----------------------------------

REFRIGERATION PLANT WORKING PRESSURES AND TEMPERATURES

Condensation	Cycle startup	End of cycle (ice-cream ready)
+ 35° C = 12,5 Bar 95° F = 225 Psi	-20° C = 2 Bar -5° F = 23,5 Psi	-33° C = 0,8 Bar -27,4° F = 12 Psi

The machine is supplied with the above default values and settings.

TECHNOGEL CANNOT BE HELD LIABLE FOR ANY DAMAGE TO PROPERTY OR INJURY TO PERSONS ARISING FROM CHANGES MADE TO THE DEFAULT SETTINGS OR FROM THE USE OF CUTOUT FUSES OR FUSES WITH INCORRECT CHARACTERISTICS OR IN ANY EVENT FUSES DIFFERING FROM THOSE PRESCRIBED.

Refrigerator Plant : MANTEGEL 50 COOLING WATER

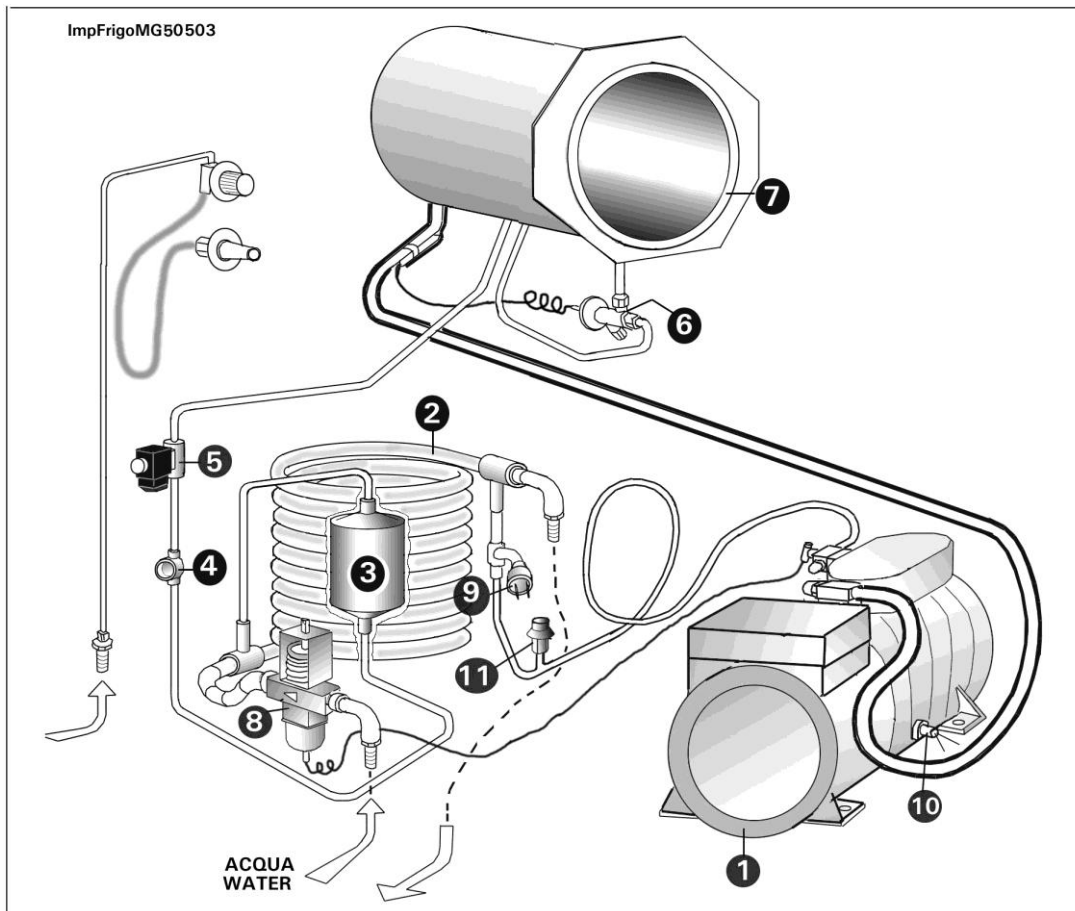

Pos.	Component Name	Code
1	Compressore frigorifero semiermetico - 220-240V/380-415V 50HZ - 220-240V 60HZ - 200V 50-60HZ	CP-19337.4 CP-19339.4 ME1-0125/2B
2	Condensatore in rame a tubi concentrici	CD-11126.6
3	Filtro deidratore	CD-14764.6
4	Spia del liquido e verifica umidità	CD-16612.6
5	Valvola solenoide senza Bobina elettrica - solo Bobina elettrica 24V 50-60HZ	FR6-0319 VV-5616.6
6	Valvola termostatica di espansione	VT-15420.4
7	Tubo congelatore evaporatore isolato	ME-4965.3IS
8	Valvola pressostatica dell' acqua	VT-17910.6
9	Pressostato di alta pressione a taratura fissa	TR-19055.6
10	Resistenza elettrica per carter compressore frigorifero	ME1-0131
11	Valvola di sicurezza impianto frigorifero	TR-18096.6

For the order of the spare parts of the refrigerator unit, as well as the code please always mention :

- 1) - Machine Type
- 2) - Serial Number
- 3) - Voltage
- 4) - Hertz

MANTEGEL 50 AIR- technical specifications

Refrigerator compressor	Semi-airtight HP 3 (KW 2,2)
Refrigerating gas	Freon R404A (quantity 1,2 Kg.)
Condenser Ventilators	N° 2 – 220V mono phase kW 0,135 cad.
Condensation	AIR

Overload cutout calibration	V.200 50/60HZ	V.220 50HZ	V.220 60HZ	V.380 50HZ	V.380 60HZ	V.415 50HZ
Compressor A.		13	13	7,5		
Dasher motor:						
- low velocity A.		11	11	9		
- high velocity A.		19	19	13,5		

Electrical fuse	V.200 e V.220	V.380 e V.415
Line protection	n°3 d. 10 x 38 32A. AM type	n°3 d. 10 x 38 25A. AM type
Compressor resist. protect.	n°1 d. 5 x 20 0,5A. rapid type	n°1 d. 5 x 20 0,5A. rapid type
F2 primary transformer	n°2 d. 5 x 20 2A. rapid type	n°2 d. 5 x 20 6,3A. delayed type
F3 secondary transformer	n°2 d. 5 x 20 6,3A. delayed type	n°2 d. 5 x 20 6,3A. delayed type
Motor blocking protection	n° 2 d. 10 x 38 16A. delayed type	n° 2 d. 10 x 38 6A. delayed type

Fixed calibration high pressure switch	Intervention pressure values (+ /-0,5 Bar)
Coutout pressure	20,7 Bar = 300 Psi
Connect pressure	13,8 Bar = 200 Psi
Differential	6,9 Bar = 100 Psi

Safety Valve	(11)	Intervention Bar 28 (+ - 0,5 Bar)
--------------	------	-----------------------------------

REFRIGERATION PLANT WORKING PRESSURES AND TEMPERATURES

Condensation	Cycle startup	End of cycle (ice-cream ready)
+ 35° C = 12,5 Bar 95° F = 225 Psi	-20° C = 2 Bar -5° F = 23,5 Psi	-33° C = 0,8 Bar -27,4° F = 12 Psi

The machine is supplied with the above default values and settings.

TECHNOGEL CANNOT BE HELD LIABLE FOR ANY DAMAGE TO PROPERTY OR INJURY TO PERSONS ARISING FROM CHANGES MADE TO THE DEFAULT SETTINGS OR FROM THE USE OF CUTOUT FUSES OR FUSES WITH INCORRECT CHARACTERISTICS OR IN ANY EVENT FUSES DIFFERING FROM THOSE PRESCRIBED.

Refrigerator Plant : MANTEGEL 50 COOLING ARIA

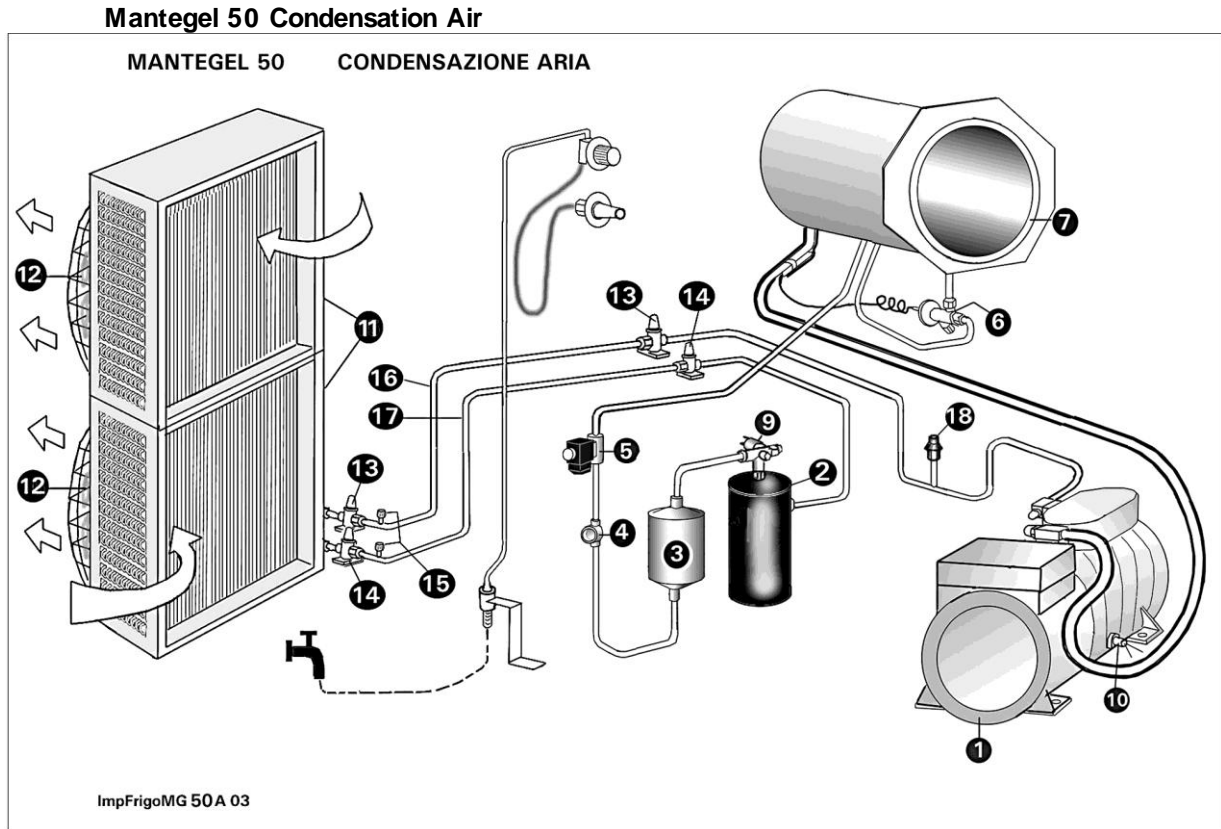

Pos.	Component Name	Code
1	Compressore frigorifero semiermetico - 220-240V/380-415V 50HZ - 220-240V 60HZ - 200V 50-60HZ	CP-18890.4 CP-16872.6 ME1-0125/2B
2	Ricevitore di liquido	
3	Filtro deidratatore	CD-14764.6
4	Spia del liquido e segnalatore di umidità	CD-16612.6
5	Valvola solenoide senza Bobina elettrica - solo Bobina elettrica	FR6-0319 VV-5616.6
6	Valvola termostatica di espansione	VT-15430.4
7	Tubo congelatore evaporatore	ME-4965.3IS
9	Pressostato alta pressione a taratura fissa	TR-19055.6
10	Resistenza elettrica carter compressore frigorifero	ME1-0131
11	Condensatore ad aria	CD-9124.6/10
12	Ventilatori condensatore	
18	Valvola di sicurezza del circuito frigorifero	TR-18096.6

For montage condenser air isolate:

13	Rubinetti per tubo di mandata	
14	Rubinetti per tubo di ritorno	
15	Valvole per effettuare il vuoto alle tubazioni di mandata e ritorno	
16	Tubazione di mandata (in rame o flessibile) da predisporre in opera	
17	Tubazione di ritorno (in rame o flessibile) da predisporre in opera	

For the order of the spare parts of the refrigerator unit, as well as the code please always mention :

- 1) - Machine Type
- 2) - Serial Number
- 3) - Voltage
- 4) - Hertz

MANTEGEL 50 AIR WATER- technical specifications

Refrigerator compressor	Semi-airtight HP 3 (KW 2,2)
Refrigerating gas	Freon R404A (quantity 1,2 Kg.)
Mixer motor	750/1500 r.p.m. KW 2,6/4,8
Condenser Ventilators	N° 2 – 220V mono phase kW 0,135 cad.
Condensation	AIR Water (minimum pressure 1,5 Bar)

Overload cutout calibration	V.200 50/60HZ	V.220 50HZ	V.220 60HZ	V.380 50HZ	V.380 60HZ	V.415 50HZ
Compressor A.		13	13	7,5		
Dasher motor:						
- low velocity A.		11	11	9		
- high velocity A.		19	19	13,5		

Electrical fuse	V.200 e V.220	V.380 e V.415
Line protection	n°3 d. 10 x 38 32A. AM type	n°3 d. 10 x 38 25A. AM type
Compressor resist. protect.	n°1 d. 5 x 20 0,5A. rapid type	n°1 d. 5 x 20 0,5A. rapid type
F2 primary transformer	n°2 d. 5 x 20 2A. rapid type	n°2 d. 5 x 20 6,3A. delayed type
F3 secondary transformer	n°2 d. 5 x 20 6,3A. delayed type	n°2 d. 5 x 20 6,3A. delayed type
Motor blocking protection	n°2 d. 10 x 38 16A. delayed type	n°2 d. 10 x 38 6A. delayed type

Fixed calibration high pressure switch	Intervention pressure values (+ /-0,5 Bar)
Coutout pressure	20,7 Bar = 300 Psi
Connect pressure	13,8 Bar = 200 Psi
Differential	6,9 Bar = 100 Psi

Safety Valve	(11)	Intervention Bar 28 (+ - 0,5 Bar)
--------------	------	-----------------------------------

REFRIGERATION PLANT WORKING PRESSURES AND TEMPERATURES

Condensation	Cycle startup	End of cycle (ice-cream ready)
+ 35° C = 12,5 Bar 95° F = 225 Psi	-20° C = 2 Bar -5° F = 23,5 Psi	-33° C = 0,8 Bar -27,4° F = 12 Psi

The machine is supplied with the above default values and settings.

TECHNOGEL CANNOT BE HELD LIABLE FOR ANY DAMAGE TO PROPERTY OR INJURY TO PERSONS ARISING FROM CHANGES MADE TO THE DEFAULT SETTINGS OR FROM THE USE OF CUTOUT FUSES OR FUSES WITH INCORRECT CHARACTERISTICS OR IN ANY EVENT FUSES DIFFERING FROM THOSE PRESCRIBED.

Refrigerator Plant : MANTEGEL 50 COOLING AIR/WATER

Mantegel 50 Condensation Air / Water

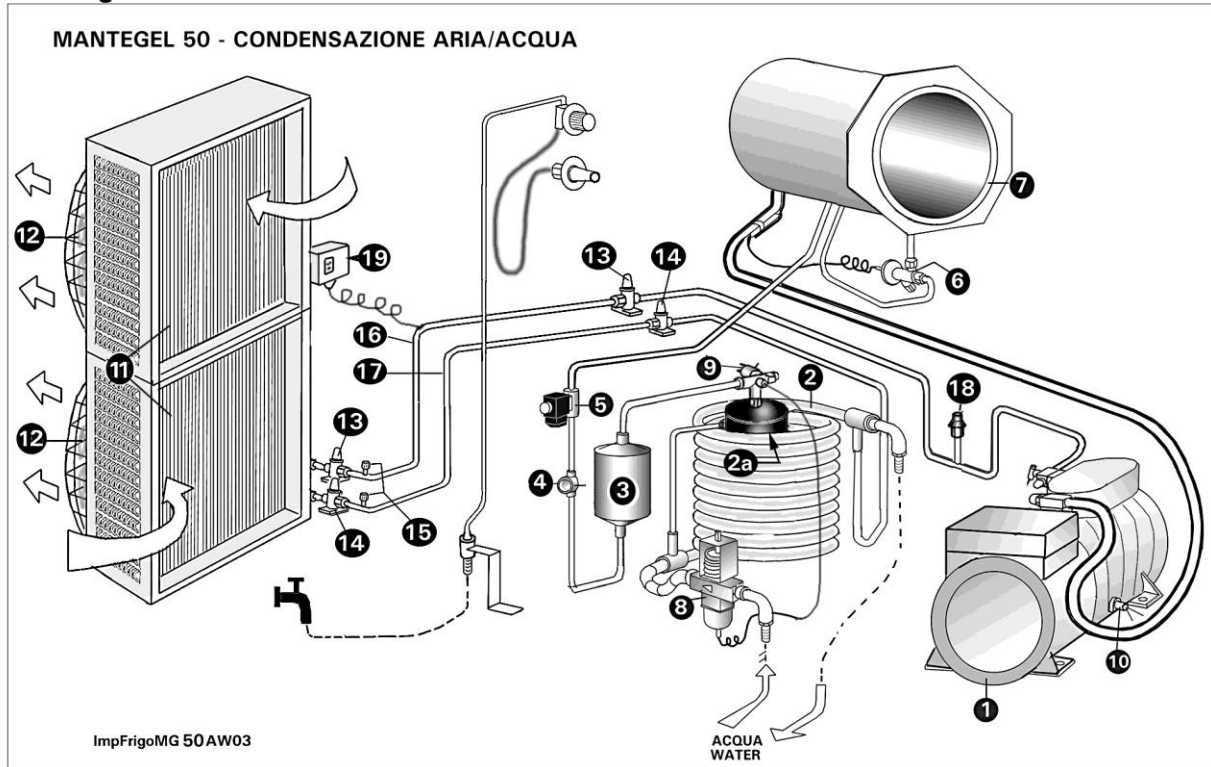

Pos.	Component Name	Code
1	Compressore frigorifero semiermetico - 220-240V/380-415V 50HZ - 220-240V 60HZ - 200V 50-60HZ	CP-15750.6 CP-16872.6 ME1-0125/2B
2	Condensatore ad acqua a tubi concentrici	CD-11126.6
2a	Ricevitore di liquido	
3	Filtro deidratatore	CD-5623.6
4	Spia del liquido e segnalatore di umidità	M2-0049
5	Valvola solenoide senza Bobina elettrica - solo Bobina elettrica 24V 50-60HZ	VV-5614.6 VV-5616.6
6	Valvola termostatica di espansione	VT-15420.4
7	Tubo congelatore evaporatore ISOLATO	ME-4965.3IS
8	Valvola pressostatica dell' acqua	MC-0039
9	Pressostato alta pressione a taratura fissa	TR-6251.6
10	Resistenza elettrica carter compressore frigorifero	ME1-0131
11	Condensatore ad aria	CD-9124.6/10
12	Ventilatori condensatore	
18	Valvola di sicurezza del circuito frigorifero	TR-18096.6
19	Pressostato intervento ventilatori condensatore ad aria	

For montage condenser air isolate:

13	Rubinetti per tubo di mandata	
14	Rubinetti per tubo di ritorno	
15	Valvole per effettuare il vuoto alle tubazioni di mandata e ritorno	
16	Tubazione di mandata (in rame o flessibile) da predisporre in opera	
17	Tubazione di ritorno (in rame o flessibile) da predisporre in opera	

For the order of the spare parts of the refrigerator unit, as well as the code please always mention :

- 1) - Machine Type
- 2) - Serial Number
- 3) - Voltage
- 4) - Hertz

MANTEGEL 70 WATER - technical specifications

Refrigerator compressor	Semi-airtight HP 4 (KW 3)
Refrigerating gas	Freon R404A (quantity 1,5 Kg.)
Mixer motor	750/1500 r.p.m. KW 4,8/7,4
Condensation	Water (minimum pressure 1 Bar)

Overload cutout calibration	V.200 50/60HZ	V.220 50HZ	V.220 60HZ	V.380 50HZ	V.380 60HZ	V.415 50HZ
Compressor A.		15	16	10,5		
Dasher motor:						
- low velocity A.		25	23,5	13,5		
- high velocity A.		29	30	17		

Electrical fuse	V.200 e V.220	V.380 e V.415
Line protection	n°9 d. 10 x 38 25A. AM type	n°9 d. 10 x 38 16A. AM type
Compressor resist. protect.	n°1 d. 5 x 20 0,5A. rapid type	n°1 d. 5 x 20 0,5A. rapid type
F2 primary transformer	n°2 d. 10 x 38 8A. AM type	n°2 d. 10 x 38 8A. AM type
F3 secondary transformer	n°2 d. 10 x 38 10A. rapid type	n°2 d. 10 x 38 10A. rapid type
Motor blocking protection	n° 2 d. 10 x 38 16A. AM type	n° 2 d. 10 x 38 8A. AM type

Fixed calibration high pressure switch	Intervention pressure values (+ /-0,5 Bar)
Coutout pressure (low pressure)	0,2 Bar = 2,9 Psi
Connect pressure (high pressure)	22 Bar = 323 Psi
Differential	0,7 Bar = 10 Psi

Safety Valve	(11)	Intervention Bar 28 (+ - 0,5 Bar)
--------------	------	-----------------------------------

REFRIGERATION PLANT WORKING PRESSURES AND TEMPERATURES

Condensation	Cycle startup	End of cycle (ice-cream ready)
+ 35° C = 12,5 Bar 95° F = 225 Psi	-20° C = 2 Bar -5° F = 23,5 Psi	-33° C = 0,8 Bar -27,4° F = 12 Psi

The machine is supplied with the above default values and settings.

TECHNOGEL CANNOT BE HELD LIABLE FOR ANY DAMAGE TO PROPERTY OR INJURY TO PERSONS ARISING FROM CHANGES MADE TO THE DEFAULT SETTINGS OR FROM THE USE OF CUTOUT FUSES OR FUSES WITH INCORRECT CHARACTERISTICS OR IN ANY EVENT FUSES DIFFERING FROM THOSE PRESCRIBED.

Refrigerator Plant : MANTEGEL 70 COOLING. WATER

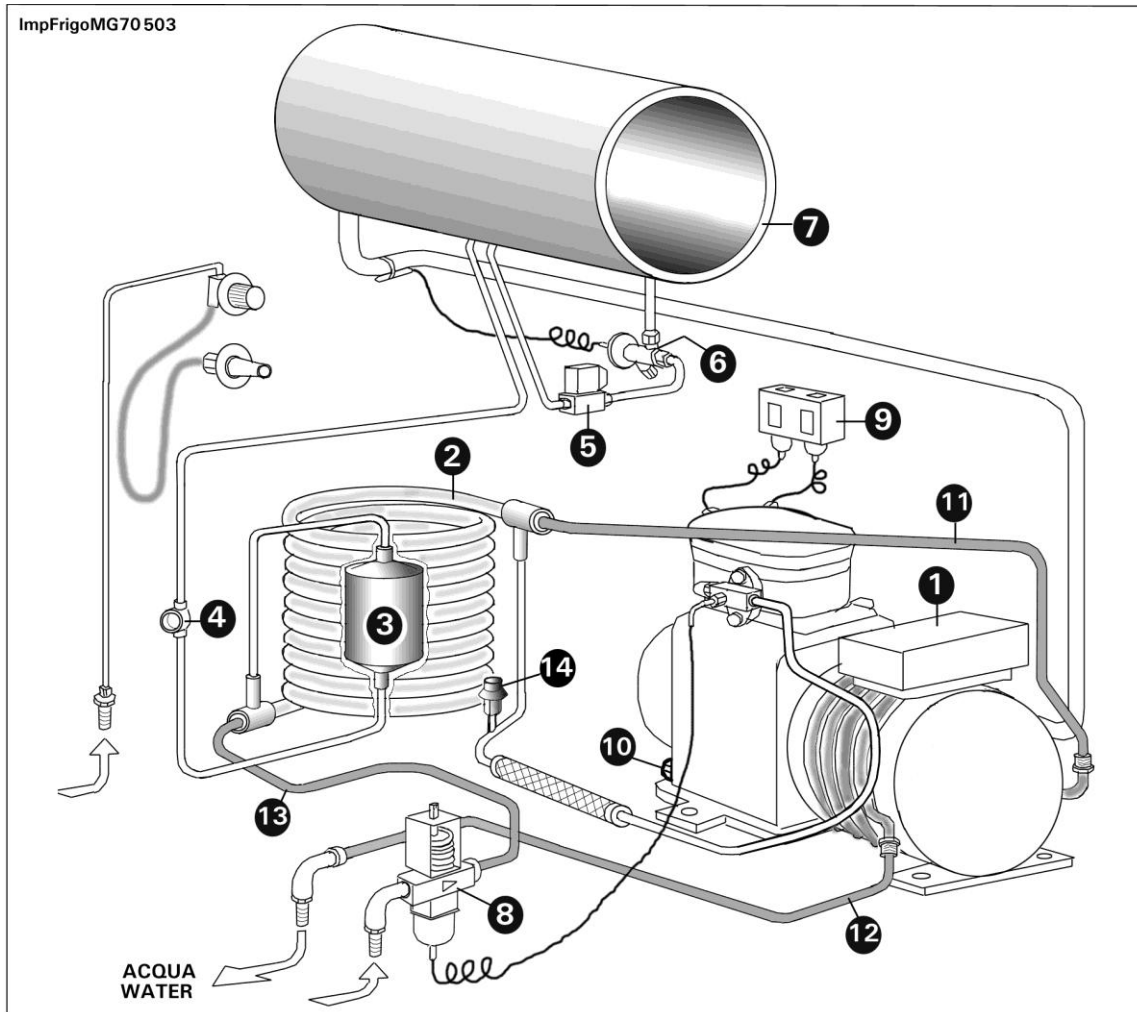

Pos.	Component Name	Code
1	Compressore frigorifero semiermetico - COPELAND 220-240V/380-415V 50HZ - DORIN 220-240V 60HZ	CP-11203.6 CP-22100.4
2	Condensatore in rame a tubi concentrici	CD-11126.6
3	Filtro deidratore	CD-14764.6
4	Spia del liquido e verifica umidità	CD-16612.6
5	Valvola solenoide senza Bobina elettrica - solo Bobina elettrica 24V 50-60HZ	FR6-0319 VV-5616.6
6	Valvola termostatica di espansione	VT-15421.4
7	Tubo congelatore evaporatore isolato	ME-4382.3/10IS
8	Valvola pressostatica dell' acqua	VT-17910.6
9	Pressostato di alta e bassa pressione	TR-5714.6
10	Resistenza elettrica per carter compressore frigorifero	DORIN FR3-0004 COPELAND CP-0012
11	Tubo gomma acqua compressore/condensatore	
12	Tubo gomma acqua compressore/scarico	
13	Tubo gomma acqua valvola pressostatica/condensatore	
14	Valvola di sicurezza impianto frigorifero	TR-18096.6

For the order of the spare parts of the refrigerator unit, as well as the code please always mention :

- 1) - Machine Type
- 2) - Serial Number
- 3) - Voltage
- 4) - Hertz

Electrical Plant

□ Electrical abbreviations

TT1	=	1st speed motor contactor
TT2	=	2nd speed motor contactor
TTC	=	Refrigerator compressor contactor
Y	=	Star closing contactor
RT1	=	1st speed motor thermal relay
RT2	=	2nd speed motor thermal relay
RTC	=	Refrigerator compressor thermal relay
TT	=	Main transformer
TE	=	Electronic transformer
TA	=	Amperometric transformer
START	=	Start pushbutton
IF	=	Flange switch
HP	=	Gas pressure switch
VS	=	Gas solenoid valve
F1	=	Main fuse
F2	=	First transformer fuse
F3	=	Second transformer fuse
PA	=	Push-button panel
AD	=	Amperometric board with display
SF	=	Blocking system electronic board

Electrical Plant: MANTEGEL 20



MANTEGEL 20 EUROa

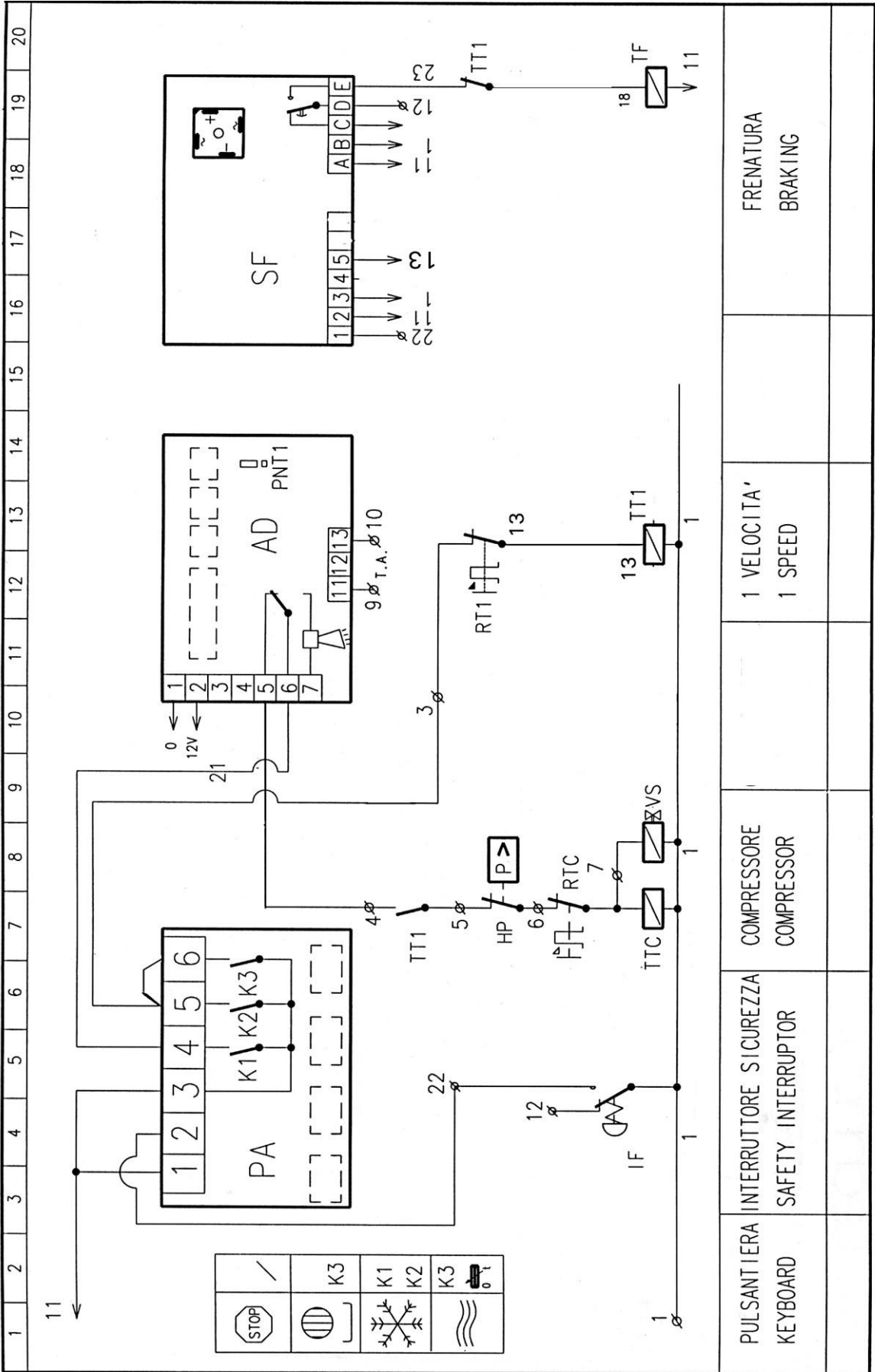

PULSANTIERA KEYBOARD	INTERRUPTORE SICUREZZA SAFETY INTERRUPTOR	COMPRESSORE COMPRESSOR	1 VELOCITA' 1 SPEED	FRENATURA BRAKING

Electrical Plant: MANTEGEL 20



MANTEGEL 20 EUROb

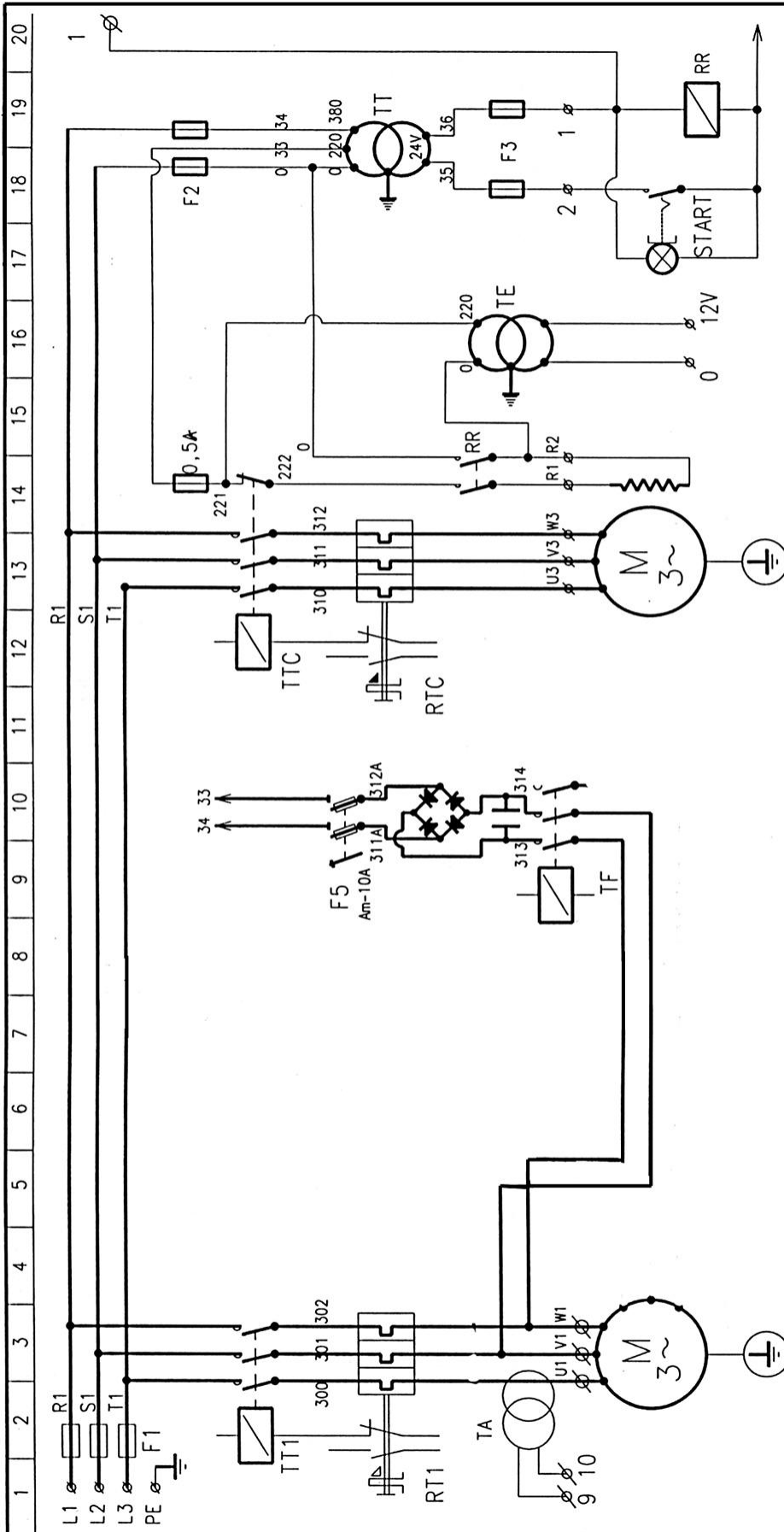

MOTORE 1 VELOCITA' 1 SPEED	FRENOTURA BRAKING	COMPRESSORE COMPRESSOR	TRASFORMATORE TRANSFORMER	TRASFORMATORE TRANSFORMER
MANTEGEL 20 KW 1.3		KW 1.3	KW 0.010	KW 0.1

Electrical Plant: MANTEGEL 30 – 50 Condenser Air Water



Macchina: MANTEGEL
 N.Dis: ME-20406.4
 Foglio 1 di 2 Data 04/05

MANTEGEL CON FRENATURA ARIA ACQUA

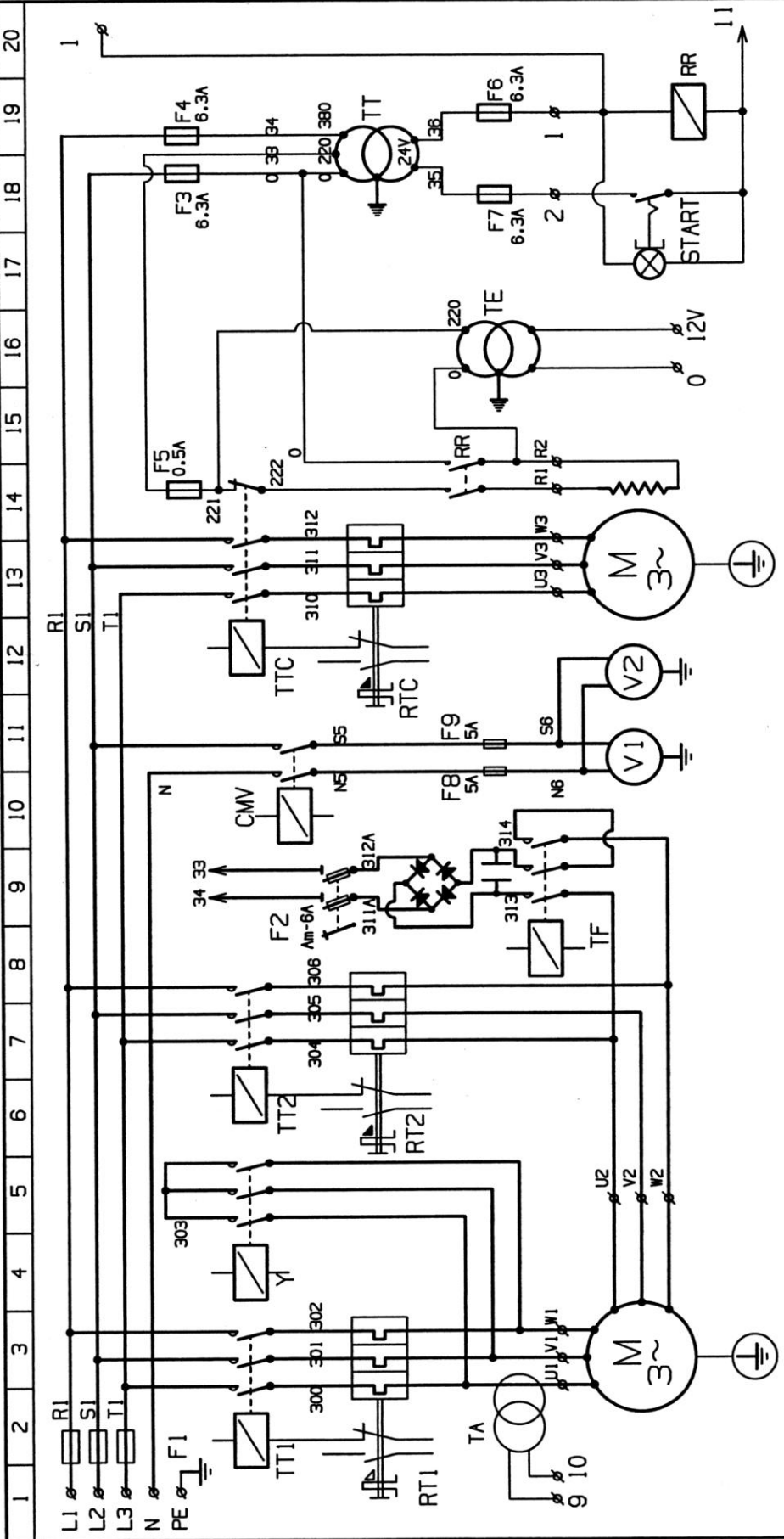

MOTORE 1 VELOCITA' 1 SPEED	CHIUSURA STELLA Y MAKE	2 VELOCITA' 2 SPEED	FRENATURA BRAKING	VENTILATORI FANS	COMPRESSORE COMPRESSOR	TRASFORMATORE TRANSFORMER	TRASFORMATORE TRANSFORMER
MANTEGEL 30 KW 1.32		KW 2.6		KW 0.135	KW 1.5	KW 0.010	KW 0.1
MANTEGEL 50 KW 2.1		KW 3.7		KW 0.135	KW 2.2	KW 0.010	KW 0.1

Electrical Plant: MANTEGEL 30 - 50 Condenser Air Water



Macchina:	MANTEGEL
N.Dis:	ME-20406.4
Foglio	2 di 2
Data	04/05

MANTEGEL CON FRENATURA ARIA ACQUA

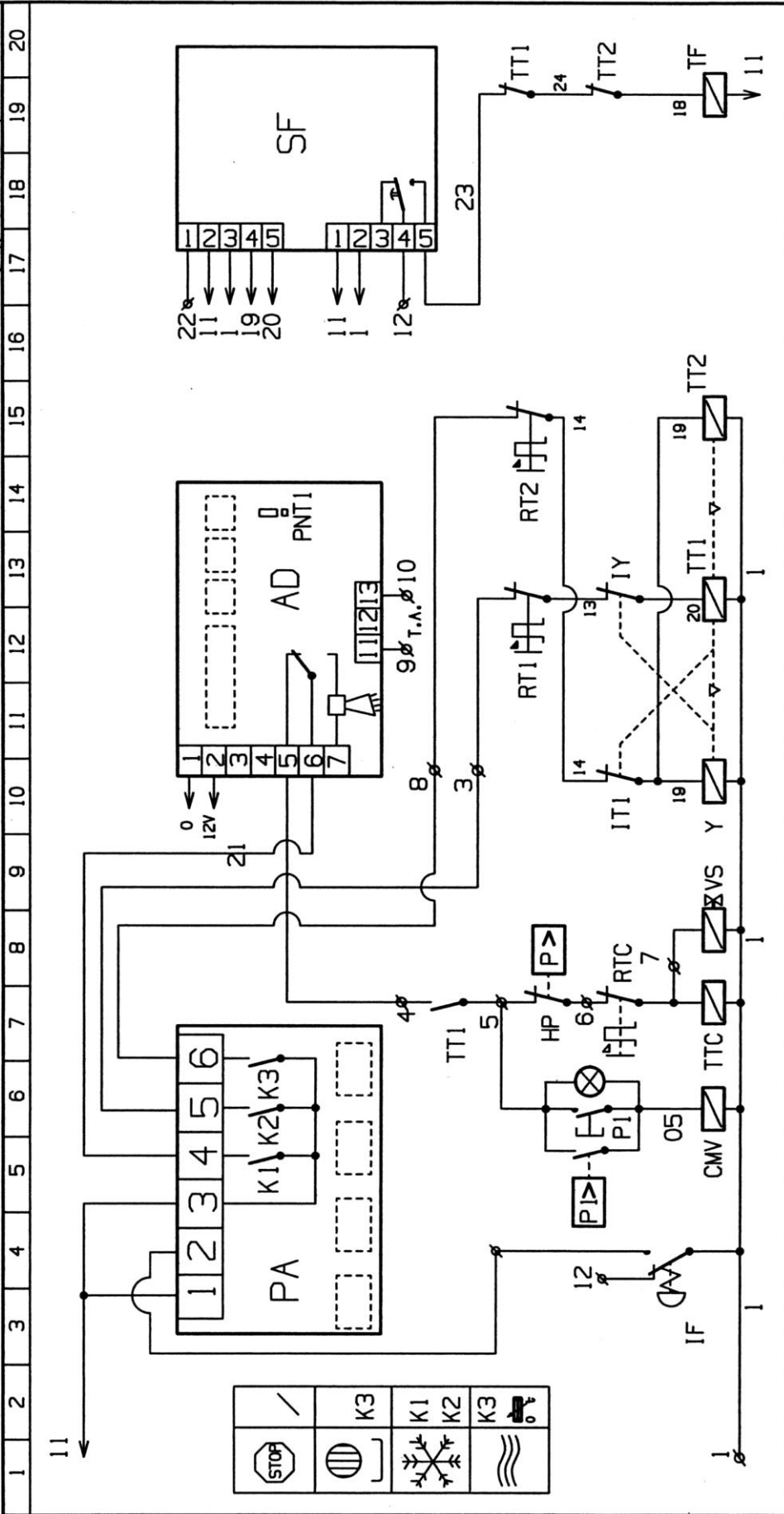

PULSANTIERA KEYBOARD	INTERR. SICUR. SAFETY INTERR.	VENTILATORI FANS	COMPRESSORE COMPRESSOR	CHIUSURA STELLA Y MAKE	1 VELOCITA' 1 SPEED	2 VELOCITA' 2 SPEED	FRENATURA BRAKING

Electrical Plant: MANTEGEL 30 - 50 Condenser Air



MANTEGEL CON FRENATURA ARIA

Macchina: MANTEGEL
 N.Dis: ME-20407.4
 Foglio 1 di 2 Data 04/05

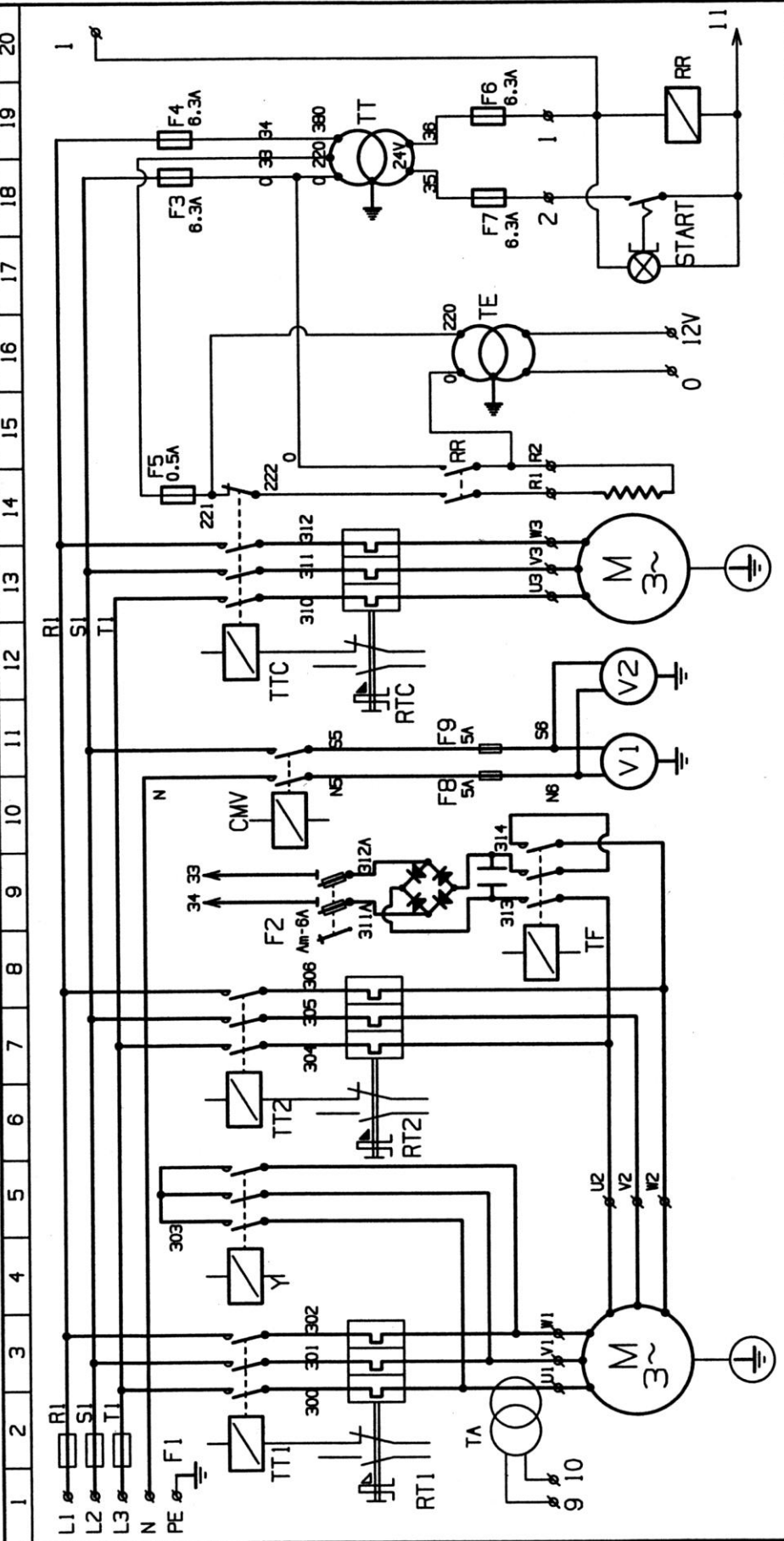

MOTORE 1 VELOCITA' 1 SPEED	CHIUSURA STELLA Y MAKE	2 VELOCITA' 2 SPEED	FRENATURA BRAKING	VENTILATORI FANS	COMPRESSORE COMPRESSOR	TRASFORMATORE TRANSFORMER	TRASFORMATORE TRANSFORMER
MANTEGEL 30 KW 1.32		KW 2.6		KW 0.135	KW 1.5	KW 0.010	KW 0.1
MANTEGEL 50 KW 2.1		KW 3.7		KW 0.135	KW 2.2	KW 0.010	KW 0.1

Electrical Plant: MANTEGEL 30 - 50 Condenser Air



Macchina:	MANTEGEL
N.Dis:	ME-20407.4
Foglio 2 di 2	Data 04/05

MANTEGEL CON FRENATURA ARIA

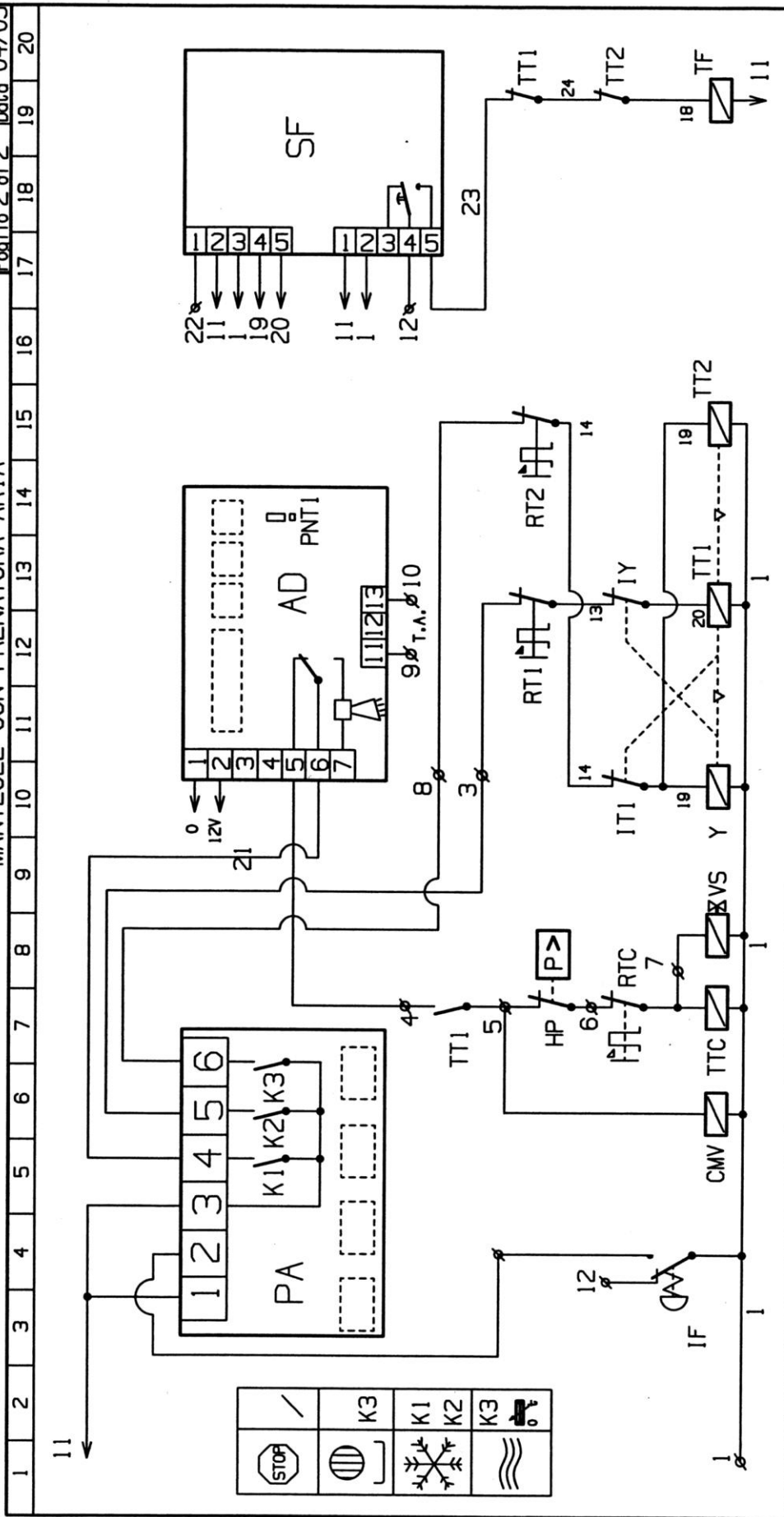

PULSANTIERA KEYBOARD	INTERR. SICUR. SAFETY INTERR.	VENTILATORI FANS	COMPRESSORE COMPRESSOR	CHIUSURA STELLA Y MAKE	1 VELOCITA' 1 SPEED	2 VELOCITA' 2 SPEED	FRENATURA BRAKING
-------------------------	----------------------------------	---------------------	---------------------------	---------------------------	------------------------	------------------------	----------------------

Electr Plant: MANTEGEL 30 50 Condenser Inverter Air Water



Macchina:	MANTEGEL
N° Dis.:	ME-20408.4
Foglio	1 di 2 Data 4/99

MANTEGEL INVERTER ARIA ACQUA

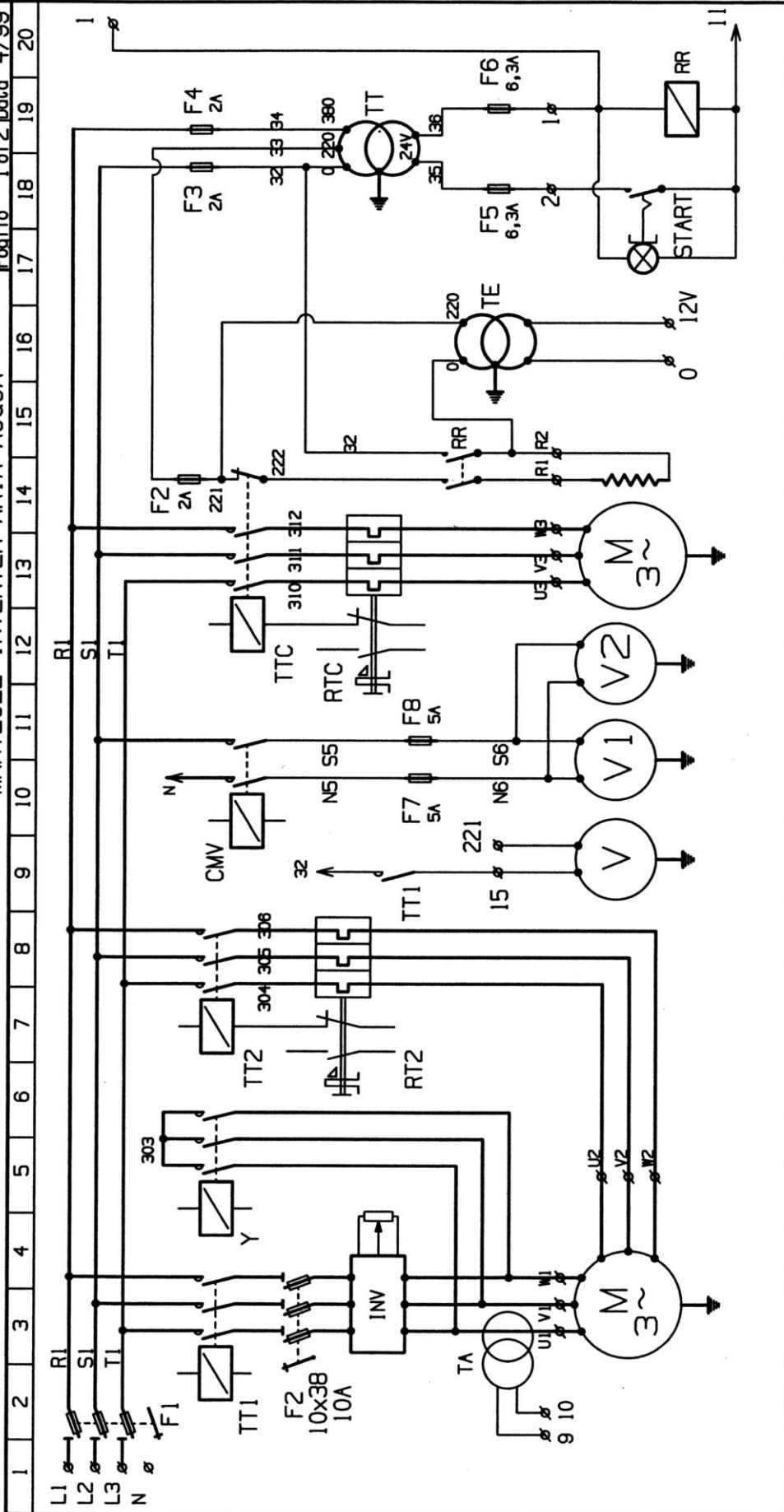

MOTORE TURBINA 1 VELOCITA'	CHIUSURA STELLA	MOTORE AGITATORE 2 VELOCITA'	VENTILAT. MOTORE	VENTILAT.	COMPRESSORE	TRASFORMATORE PRINCIPALE	TRASFORMATORE ELETTRONICA
MANTEGEL 30 KW 1.32		KW 2.6	KW 0.036	KW 0.135	KW 1.5	KW 0.01	KW 0.1
MANTEGEL 50 KW 2.1		KW 3.	KW 0.036	KW 0.135	KW 2.2	KW 0.01	KW 0.1

Electr Plant: MANTEGEL 30 50 Condenser Inverter Air Water



MANTEGEL INVERTER ARIA ACQUA

Macchina:	MANTEGEL
N.Dis:	ME-20408.4
Foglio	2 di 2
Data	4/99

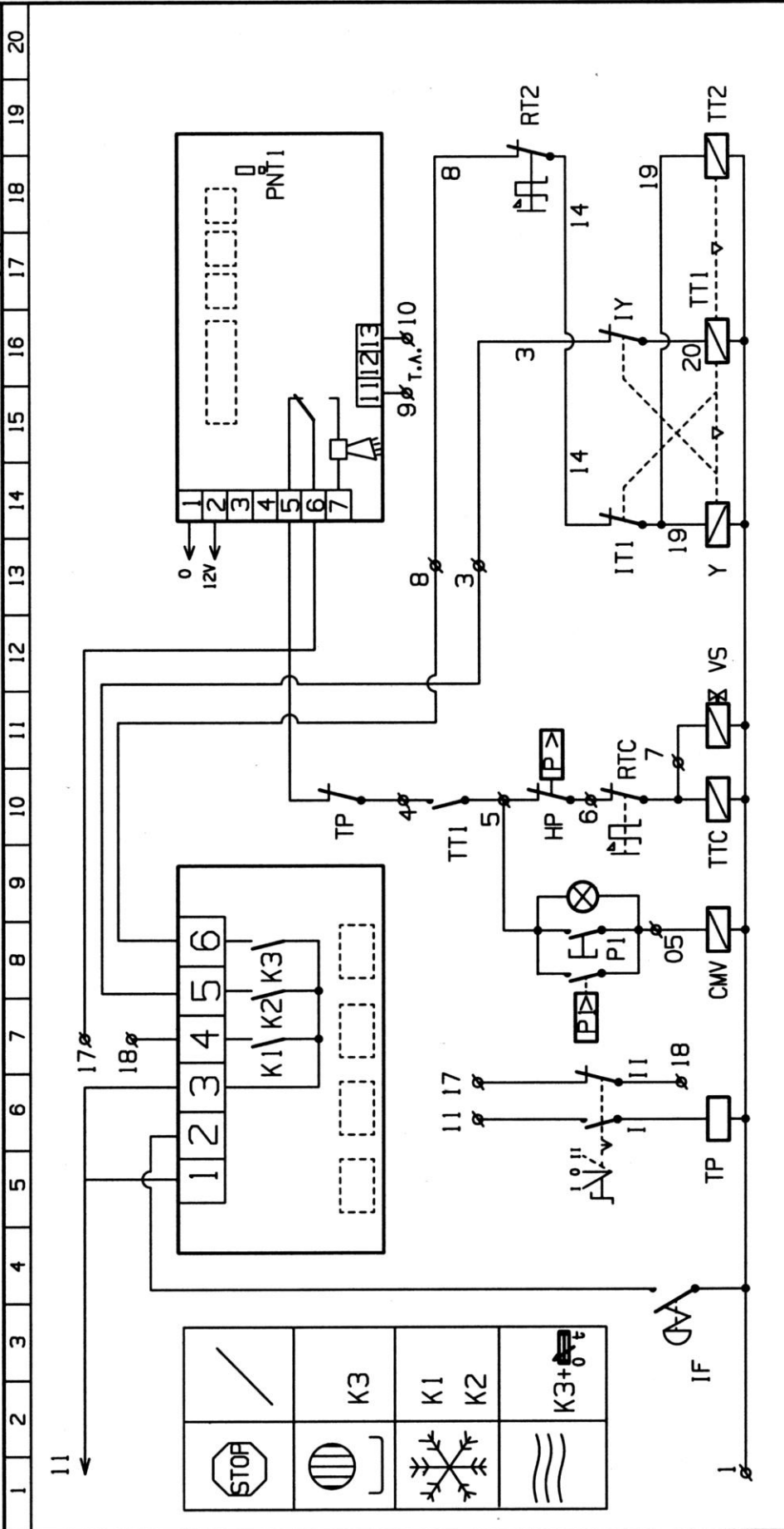

PULS.	INTERRUTTORE SICUREZZA FLANGIA	TEMPORIZZ.	VENTILATORI	COMPRESSORE SOLENOIDE GAS	CHiusura STELLA	MOTORE 1° VELOCITA'	MOTORE 2° VELOCITA'

Electrical Plant: MANTEGEL 30 e 50 for "GRANITA"



MANTEGEL 30 - MANTEGEL 50 "GRANITA"

Macchina: MANTEGEL
 N.Dis: ME-8962.4/10
 Foglio 1 di 2 Data 4/99

ImpoEletMGgranitaA

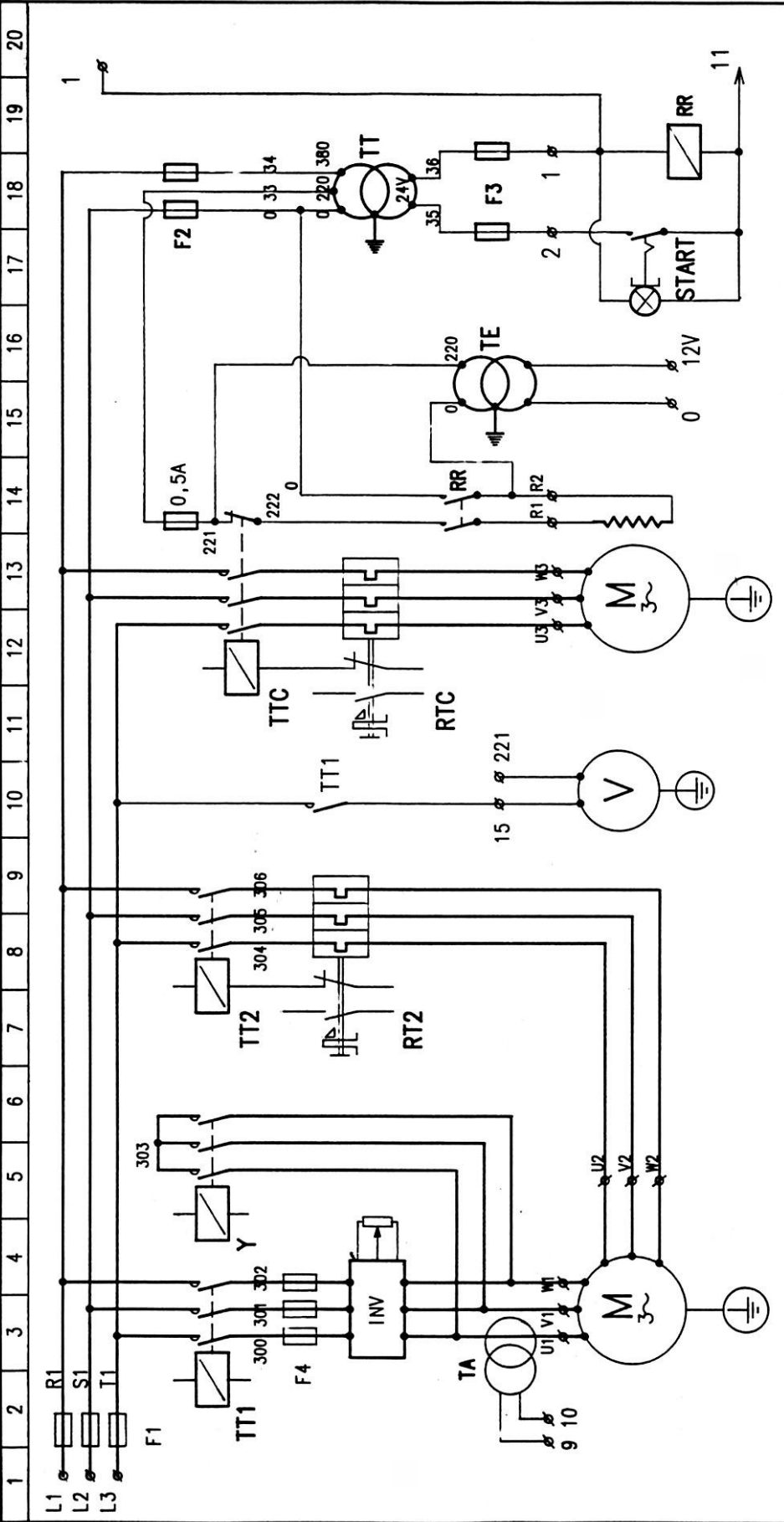

	MOTORE TURBINA 1 VELOCITA' 1 SPEED	CHIUSURA STELLA Y MAKE	MOTORE TURBINA 2 VELOCITA' 2 SPEED	VENTILATORE FAN	COMPRESSORE COMPRESSOR	TRASFORMATORE TRANSFORMER	TRASFORMATORE TRANSFORMER
MANTEGEL 30	KW 1.32		KW 2.6	KW 0.036	KW 1.5	KW 0.01	KW 0.1
MANTEGEL 50	KW 2.1		KW 3.7	KW 0.036	KW 2.2	KW 0.01	KW 0.1

Electrical Plant: MANTEGEL 30 e 50 for "GRANITA"

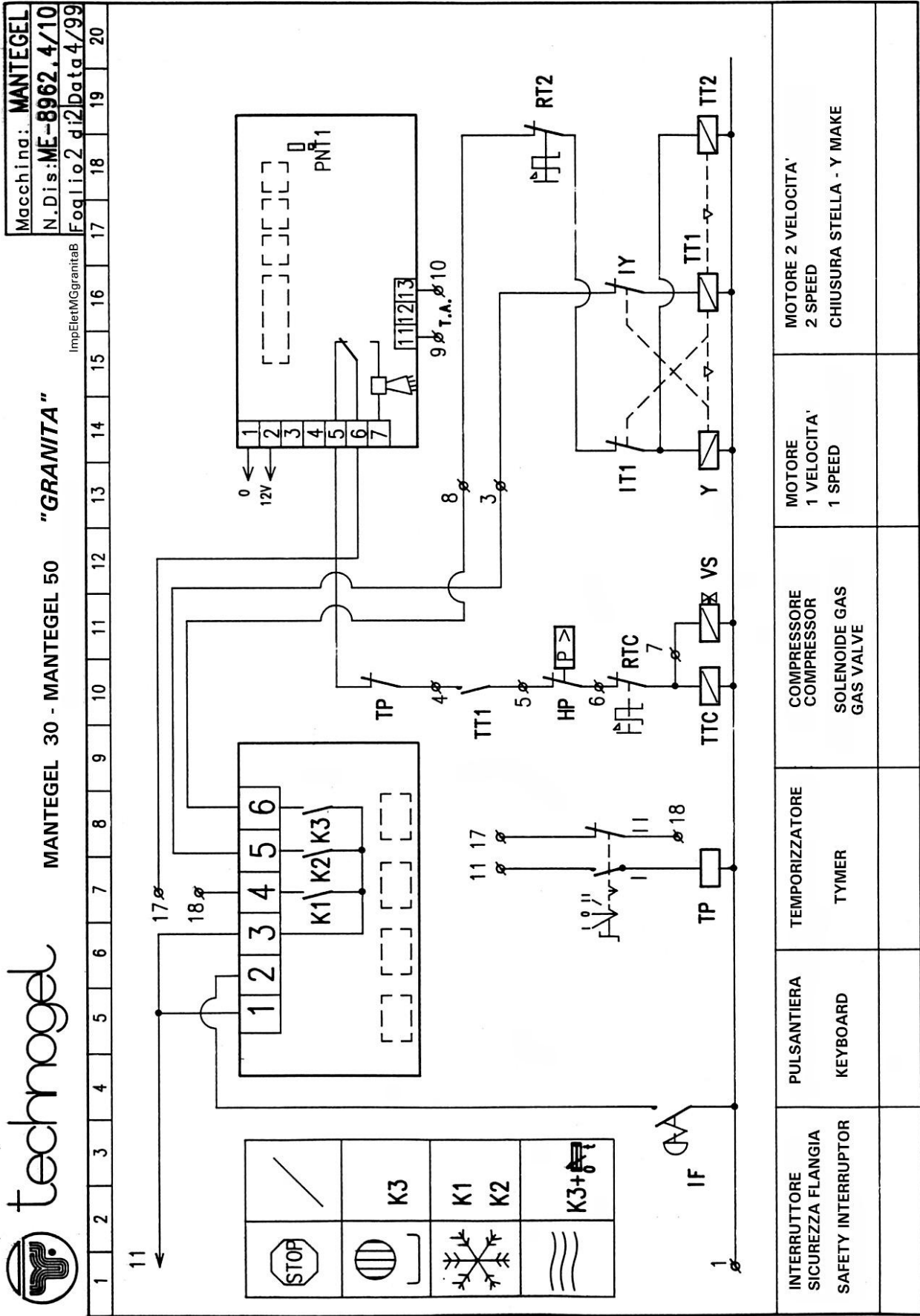

Electrical Plant: MANTEGEL 70



MANTEGEL CON FRENATURA

Macchina:	MANTEGEL
N.Dis:	ME-9681.4/40
Foglio	1 di 2
Data	10/98

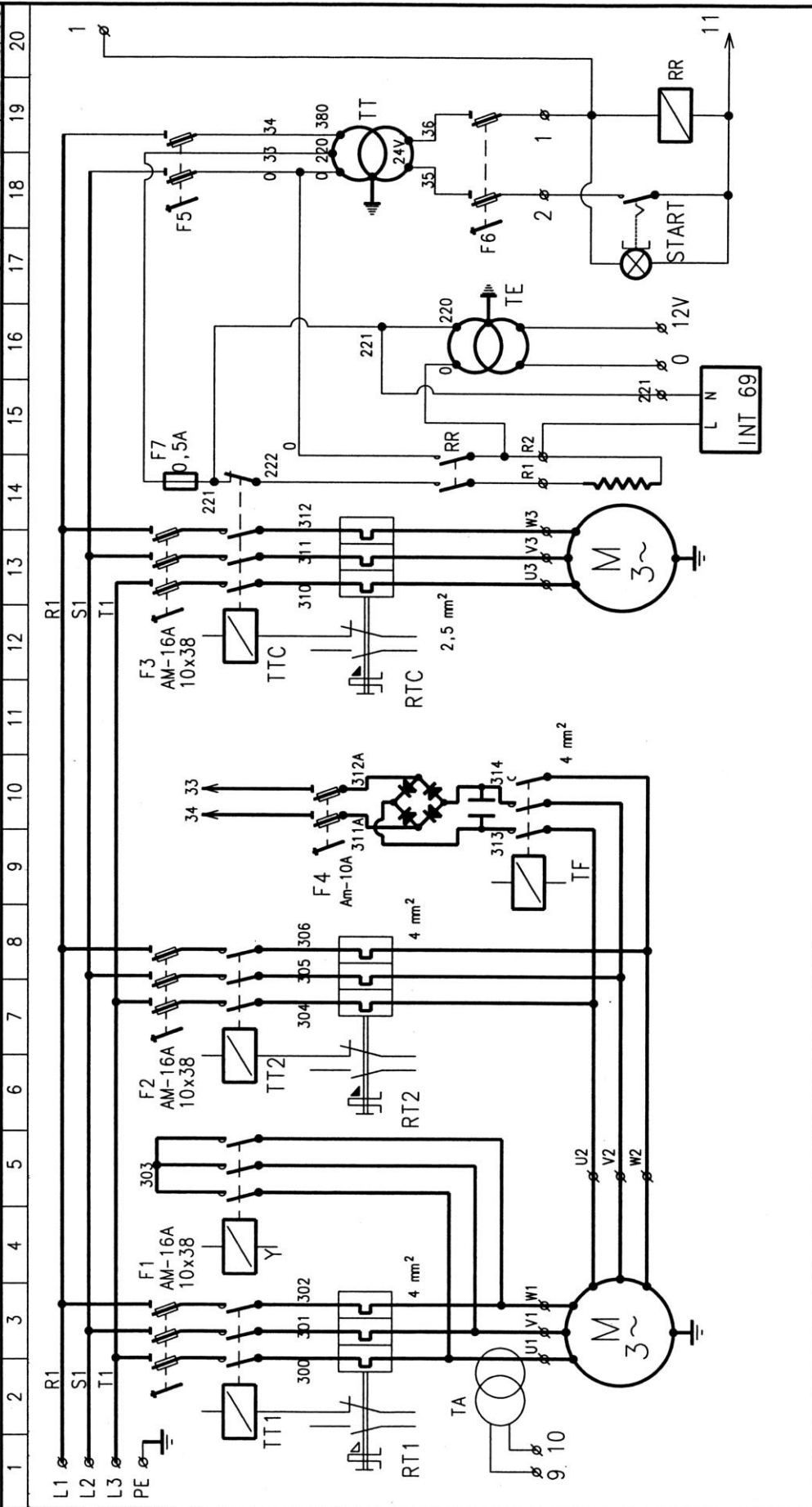

MOTORE 1 VELOCITA'	CHIUSURA STELLA	2 VELOCITA'	FRENATURA	COMPRESSORE	PROTEZIONE	TRASFORMATORE	TRASFORMATORE
1 SPEED	Y MAKE	2 SPEED	BRAKING	COMPRESSOR	COMPRESSORE	TRANSFORMER	TRANSFORMER
MANTEGEL 70	KW 4.8	KW 7.4		KW 3.67		KW 0.010	KW 0.15

Electrical Plant: MANTEGEL 70



Macchina: MANTEGEL 70
 N.Dis: ME-9681.4/40
 Foglio 2 di 2 Data: 10/98

MANTEGEL CON FRENATURA

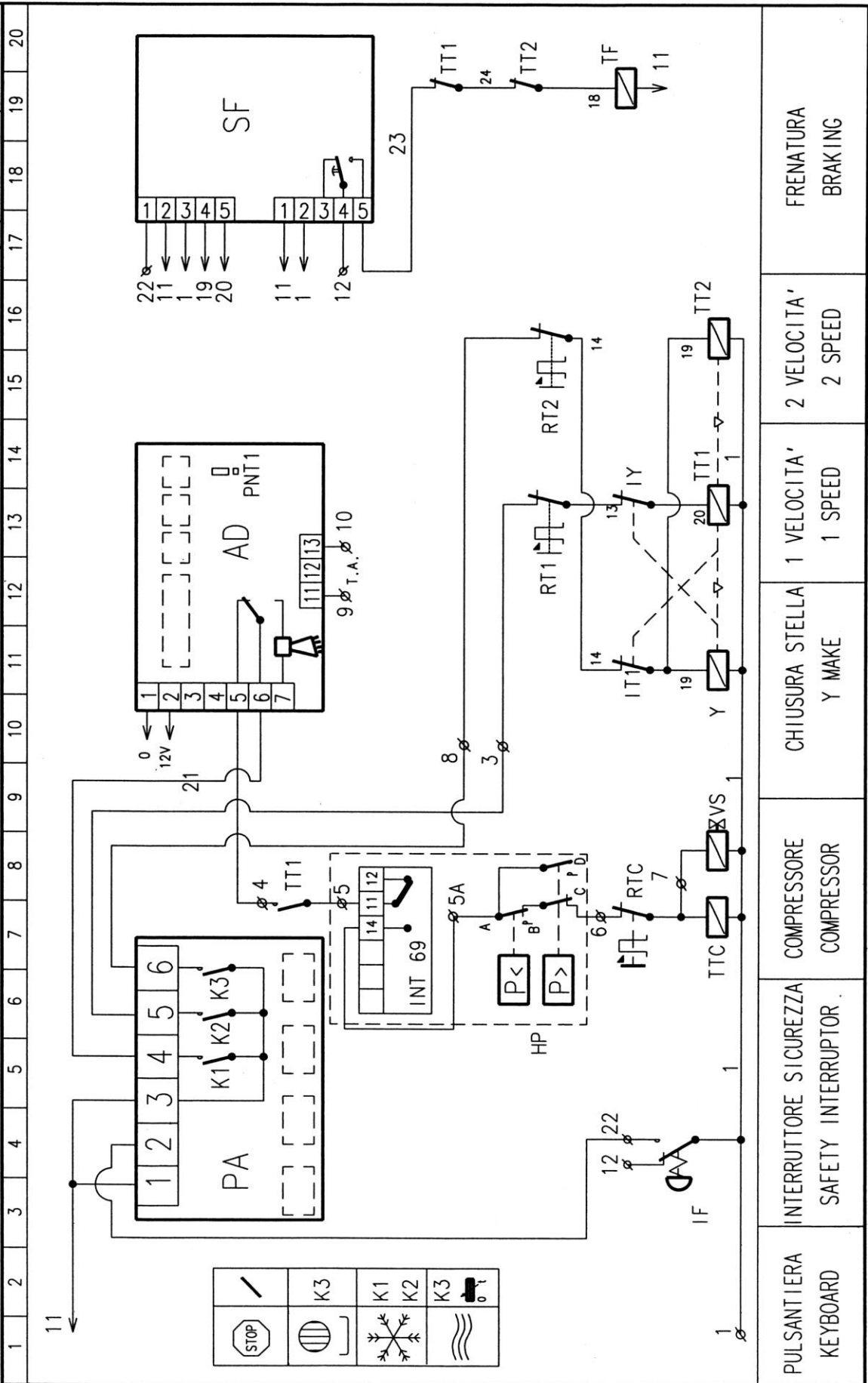

PULSANTIERA KEYBOARD	INTERRUTTORE SICUREZZA SAFETY INTERRUPTOR	COMPRESSORE COMPRESSOR	CHIUSURA STELLA Y MAKE	1 VELOCITA' 1 SPEED	2 VELOCITA' 2 SPEED	FRENATURA BRAKING
-------------------------	--	---------------------------	---------------------------	------------------------	------------------------	----------------------

⇒ Spare parts

The units that make up the machine are described in the following pages.

When ordering spare parts, always quote:

- ⇒ **Machine type**
- ⇒ **Machine registration number**
- ⇒ **Machine voltage (when ordering an electrical spare part)**
- ⇒ **Code for part when applicable, or else the number corresponding to the part and page number on which it is depicted.**

.....

Telefon: + + 39 035 4522062

Fax + + 39 035 4522682

Website: www.technogel.com

E-mail: info@technogel.com

Dasher Unit : MANTEGEL 20

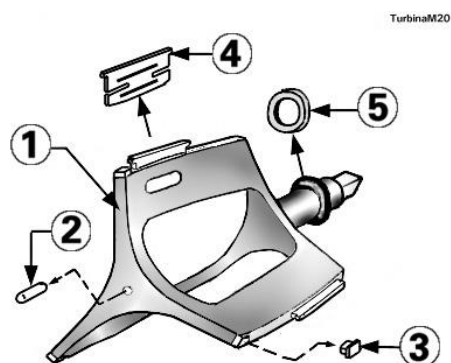

N° Pos.	N° Piec.	Name	Code
	1	Dasher complete in every detail	ME-15603.4/20
1	1	Dasher body	ME-15604.2
2	1	Ratchet	ME-3912.0/10
3	3	Dasher centring block	ME-11172.0
4	3	Scraping blade	ME-11171.0/10
5	1	Dasher seal gasket	GU-3903.0/10

⇒ Dasher Unit : MANTEGEL 30

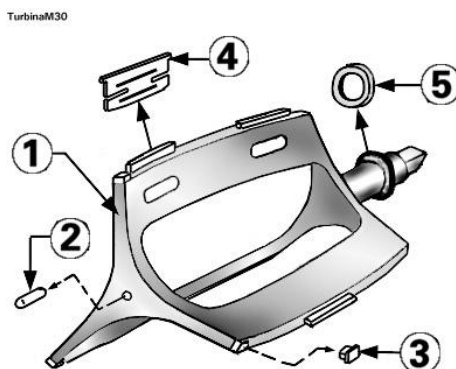

N° Pos.	N° Piec.	Name	Code
	1	Dasher complete in every detail	ME-11185.4/10
1	1	Dasher body	ME-11175.2
2	1	Ratchet	ME-3912.0/10
3	3	Dasher centring block	ME-11172.0
4	3	Scraping blade	ME-11171.0/10
5	1	Dasher seal gasket	GU-3903.0/10

Dasher Unit : MANTEGEL 50

TurbinaM50

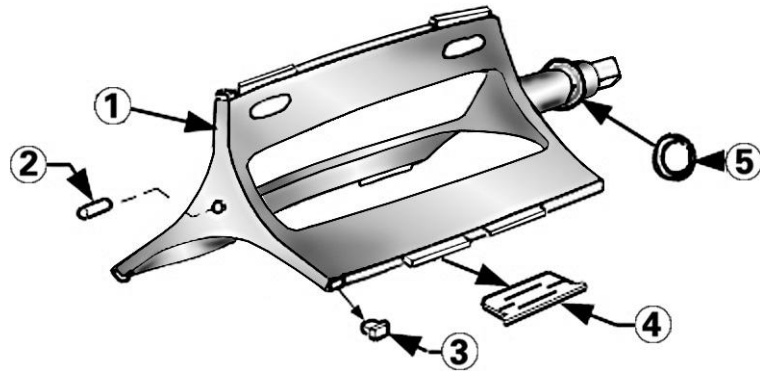

N° Pos.	N° Piec.	Name	Code
	1	Dasher complete in every detail	ME-11181.4/10
1	1	Dasher body	ME-11179.2
2	1	Ratchet	ME-3912.0/10
3	3	Dasher centring block	ME-11172.0
4	6	Scraping blade	ME-11171.0/10
5	1	Dasher seal gasket	GU-3905.0/10

⇒ Dasher Unit : MANTEGEL 70

TurbinaM70

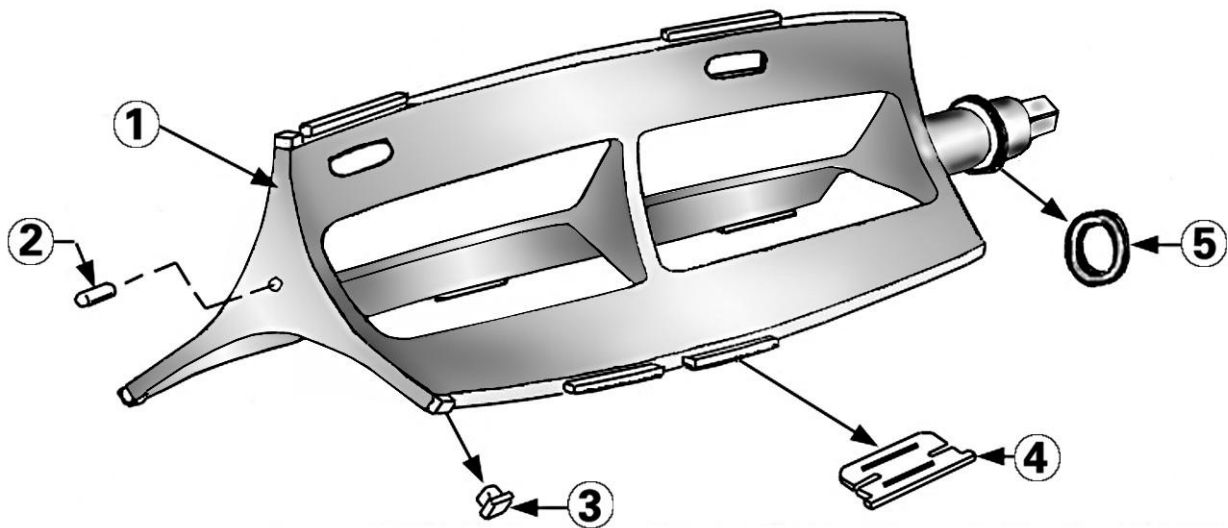

Pos.	N° Piec.	Name	Code
	1	Dasher complete in every detail	ME-11697.4/10
1	1	Dasher body	ME-11691.2
2	1	Ratchet	ME-3912.0/10
3	3	Dasher centring block	ME-11172.0
4	9	Scraping blade	ME-11171.0/10
5	1	Dasher seal gasket	GU-3906.0/10

"Console" controlling unit

mante console

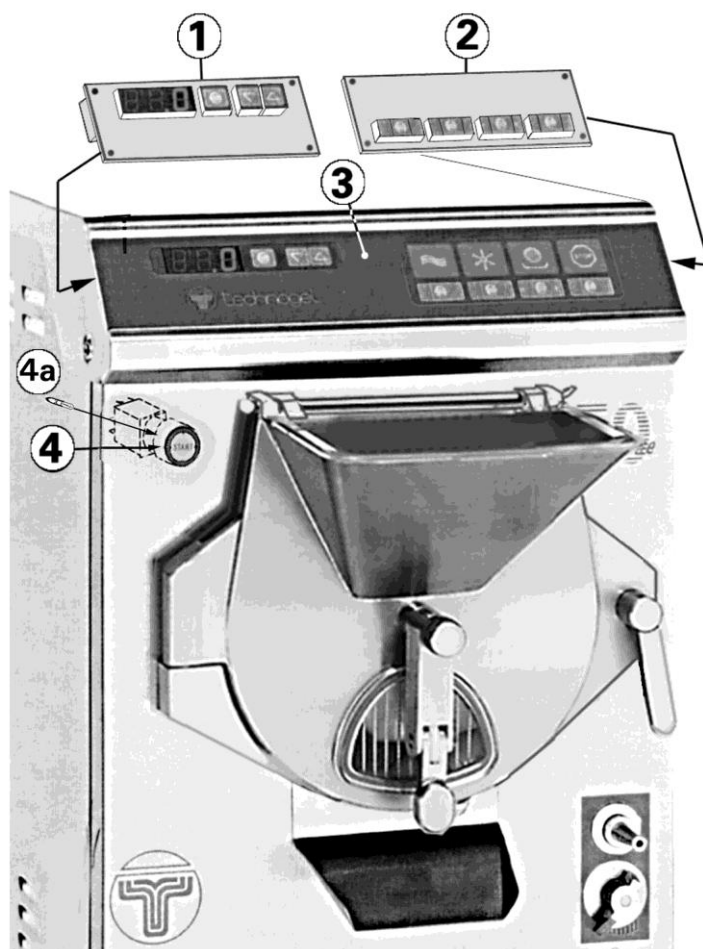

Pos.	Name	Code
1	Electronic amperometric gear-case	CC-8160.6/20
2	Push-button panel card	CC-8197.6
3	Console film (rating plate)	ME-8158.0/01
4	START switch	CC-5719.6
4a	Light 24V	CC-16657.6

NB: The parts quoted and depicted above are identical for **MANTEGEL 20 - 30 - 50 - 70.**

"Front door" unit

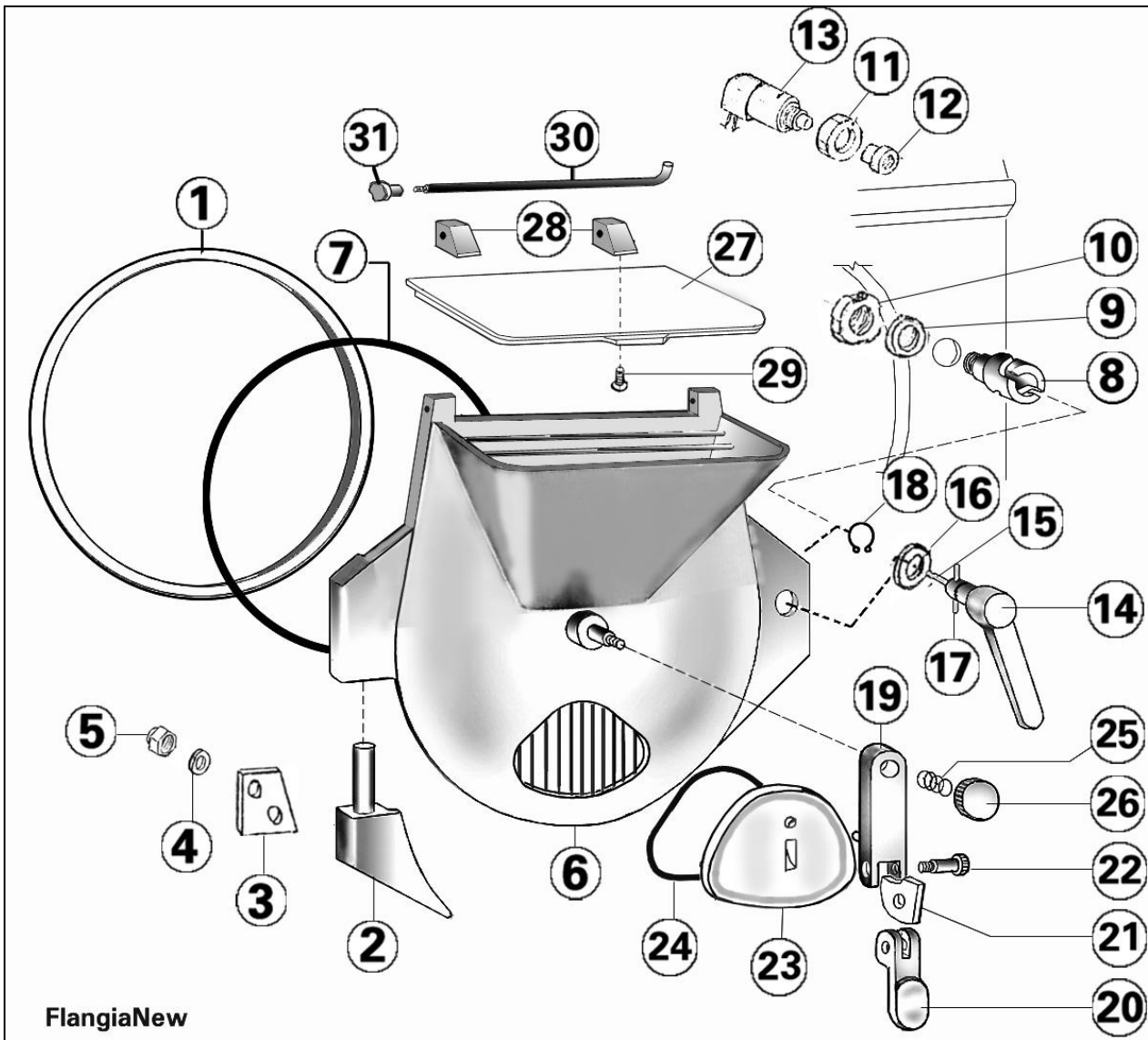

Pos.	Name	Code
1	freezer gasket	GU-4309.0/20
2	Hub hinge complete	ME-4397.3/10
3	Shim adjustament hub sp 1,5	ME-4402.0/01
4	Washer plane 10,5x21-UNI 6592	RO-I-0010
5	Nut self blocking M10 UNI 7473	DAI-0020
6	Front door body	ME-18486.3/30
7	Front door gasket	ME-0036
8	Front door block bush OR 81075	ME-15972.0/20
9	Kasher ring nut compass	ME-2542.0
10	Ring nut block compass	ME-2116.0/20
11	Ring nut clamp end run security	ME-18116.0
12	Compass for end run security	ME-18115.0/10
13	End run security	CC-18068.6
14	Front door door handle	ME-15970.2
15	Push rod	ME-15971.0
16	Washer Shim adjustament lever	ME-21014.0
17	Thorn cilynder 5x36 UNI 1707	SPCI-5X36
18	Seeger 16 E UNI 7435	SEEI-16E
19	Lever Complete	ME-8968.3/02
20	Lever Mob.	ME-8965.0
21	Cam block cap	ME-8970.0/10
22	Leve hub	ME-8964.0/01
23	Ice-cream seal cap	ME-18488.0/11
24	Cap seal gasket OR-6400	GU-18746.6
25	Lever knob	MS-0347.6
26	Flange hinge	ME-8966.0/01
27	Feedbox cover	ME-18490.0/10
28	Hinge cover tramoggia	ME-18492.0/20
29	Screw M4x10 uni 7689	TGI-0004X10
30	Hub hinge	ME-18491.0
31	Wheel	ME-18493.0

NB: The parts quoted and depicted above are identical for **MANTEGEL 20 - 30 - 50 - 70**.

Dasher draft support unit: MANTEGEL 20

TrasmissioneM20

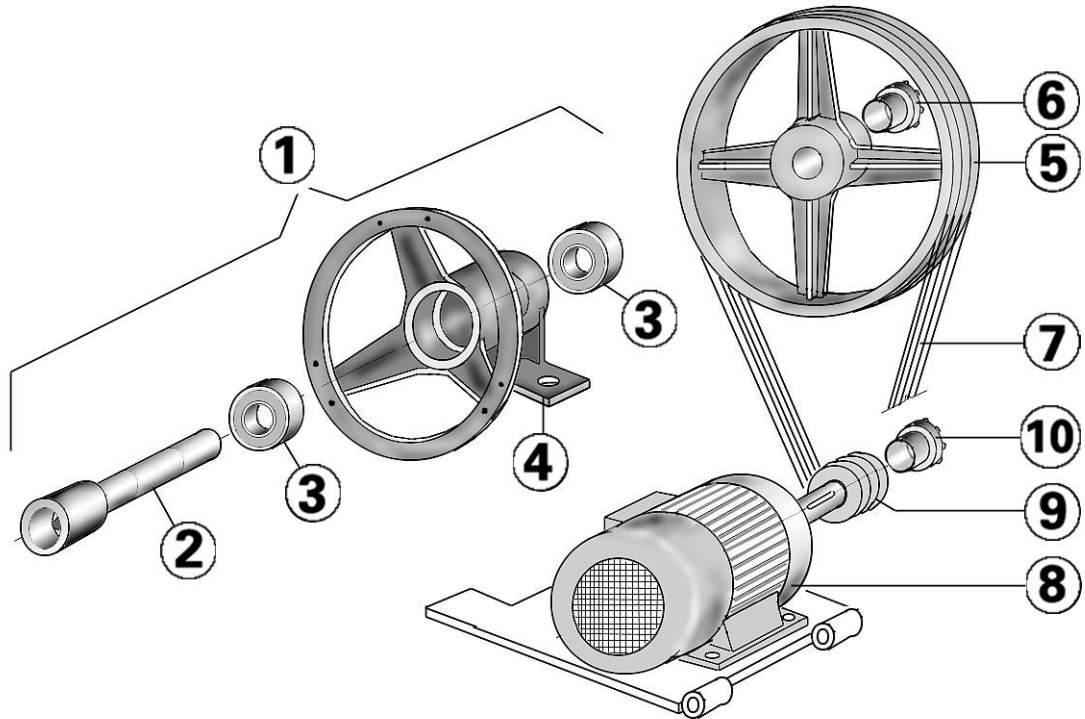

Pos.	N° Pieces	Name	Code
1	1	Complete support	ME-7136.4
2	1	Shaft support	ME-4361.2/10
3	2	Bearing support	CS-6610.6
4	1	Aluminium body support	ME-4379.0/02
5	1	Pulley support	M2-4888.0
6	1	Pulley wedge	PU-6599.6
7	3	Transmission belt A59	FR3-0131
8	1	Dasher motor	230V-400V/50Hz 220V/60Hz 380V/60Hz MO-0025 MO-15269.6 MO-15269.6
9	1	Pulley motor	M2-4368.0
10	1	Pulley wedge	PU-6600.6

ATTENTION:

If a belt needs to be replaced, all belts must be changed. There must never be a single belt replacement.

Dasher draft support unit: MANTEGEL 30 (220V-400V/50Hz)

TrasmissioneM30

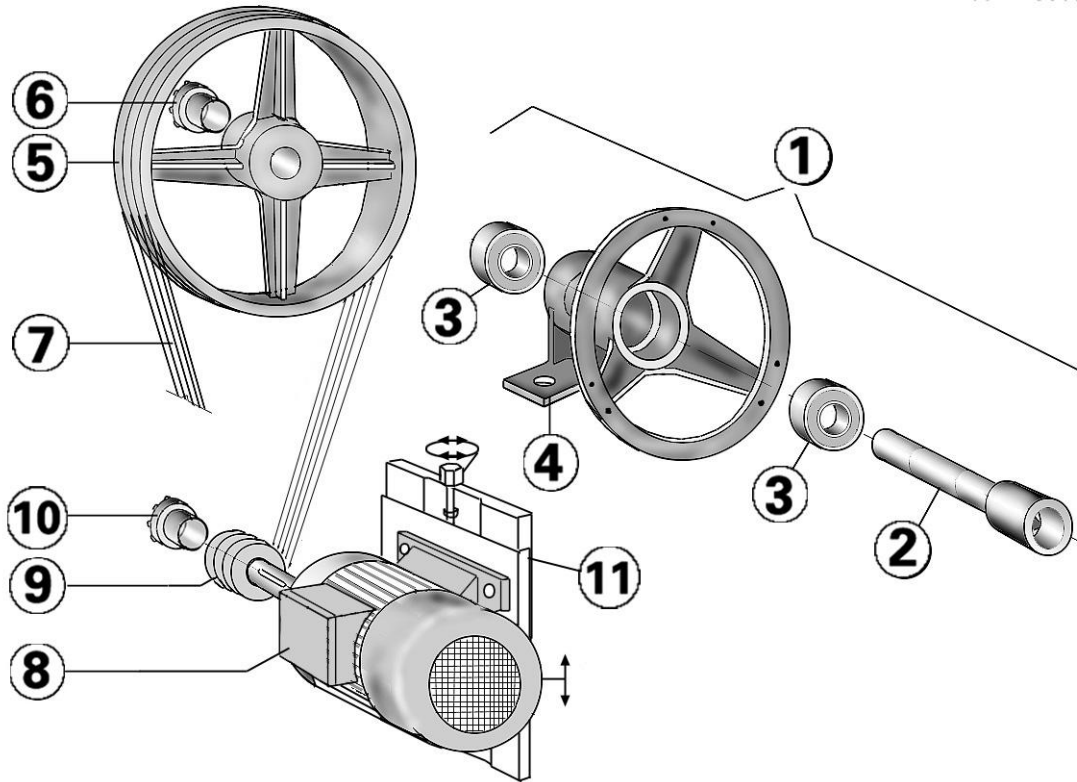

Pos.	N° Pieces	Name	Code
1	1	Complete support	ME-7136.4
2	1	Shaft support	ME-4361.2/10
3	2	Bearing support	CS-6610.6
4	1	Aluminium body support	ME-4379.0/02
5	1	Pulley support	M2-4888.0
6	1	Pulley wedge	PU-6599.6
7	3	Transmission belt A59	FR3-0131
8	1	Dasher motor	400V/50Hz MO-0014 220V/50Hz MO-0014/2
9	1	Pulley motor	PU-11173.0
10	1	Pulley wedge	PU-6601.6
		Slide	FR1-6950.6

ATTENTION:

If a belt needs to be replaced, all belts must be changed. There must never be a single belt replacement

Dasher draft support unit: MANTEGEL 30 (220V-380V/60Hz)

Trasmissione M30 Usa

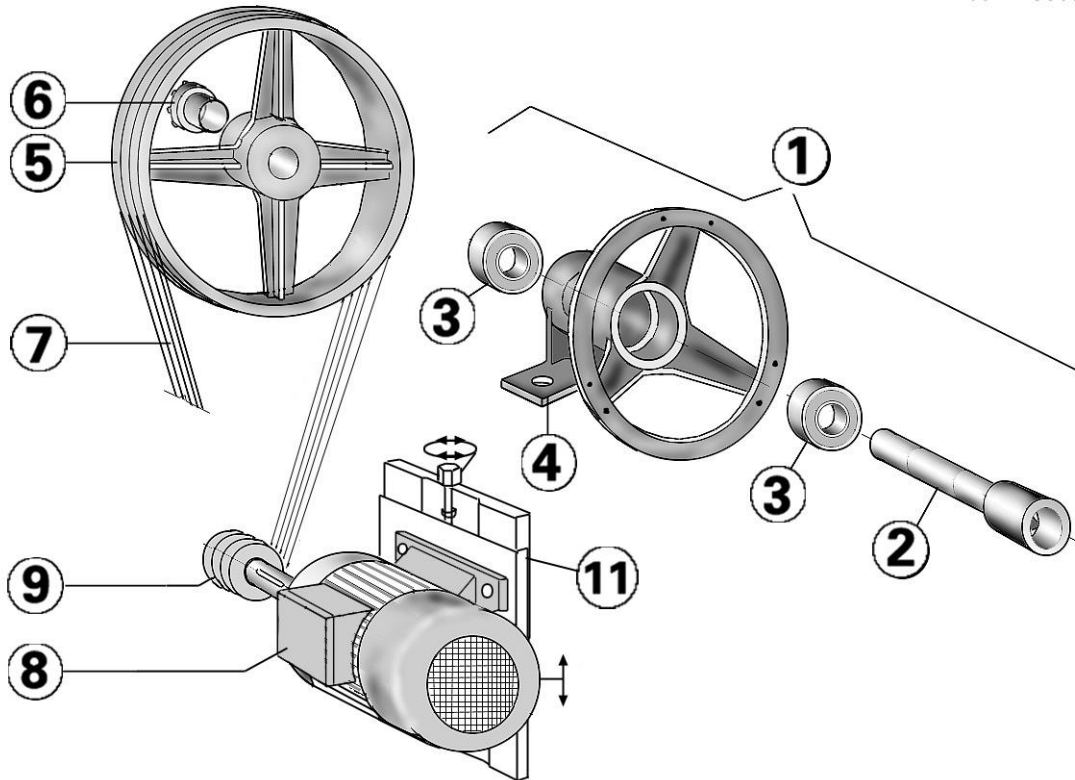

Pos.	N° Pieces	Name	Code
1	1	Complete support	ME-7136.4
2	1	Shaft support	ME-4361.2/10
3	2	Bearing support	CS-6610.6
4	1	Aluminium body support	ME-4379.0/02
5	1	Pulley support	M2-4888.0
6	1	Pulley wedge	PU-6599.6
7	3	Transmission belt A59	FR3-0131
8	1	Dasher motor	220V/60Hz 380V/60Hz
9	1	Pulley motor	PU-11173.0
		Slide	FR1-6950.6

ATTENTION:

If a belt needs to be replaced, all belts must be changed. There must never be a single belt replacement

Dasher draft support unit: MANTEGEL 50

TrasmissioneM50

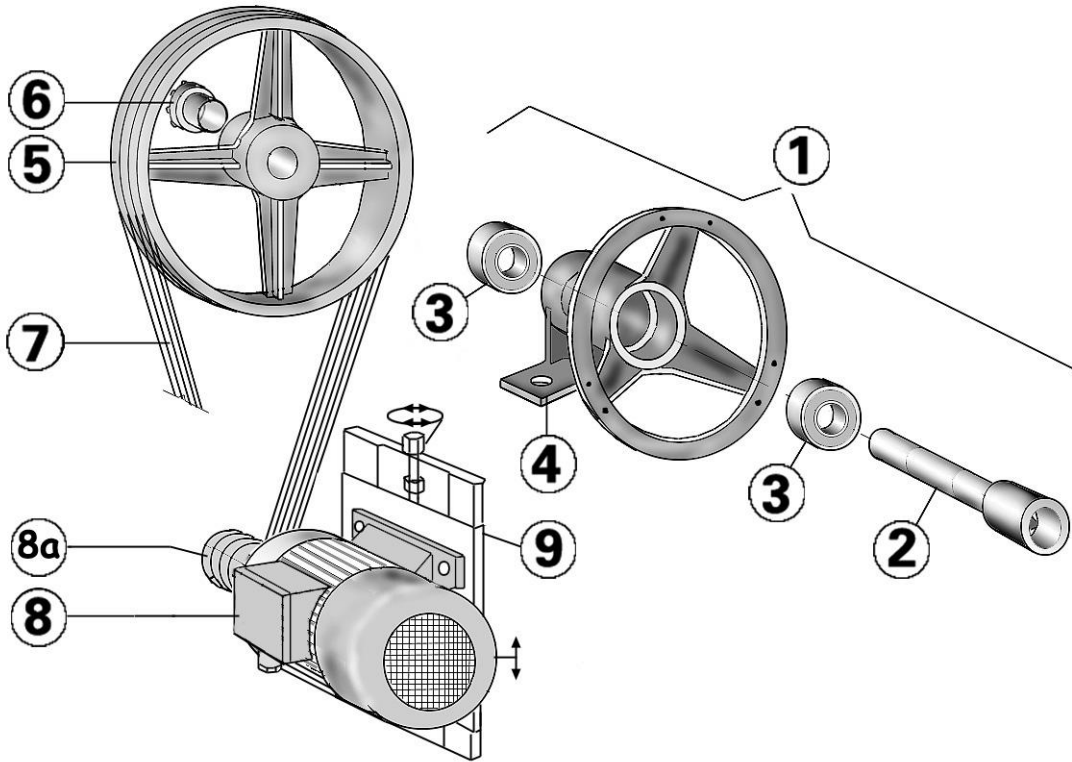

Pos.	N° Pieces	Name	Code
1	1	Complete support	ME-7137.4
2	1	Shaft support	ME-4440.2/03
3	2	Bearing support	CS-6610.6
4	1	Aluminium body support	ME-4379.0/02
5	1	Pulley support	M2-4888.0
6	1	Pulley wedge	PU-6599.6
7	3	Transmission belt A59	FR3-0131
8*	1	Dasher motor	200V/50/60Hz 220V/50Hz 380V-420V/50Hz 440V-480V/60Hz MO-7925.6/2B MO-15271.6 MO-7925.6 MO-7925.6
8a	1	Pulley motor	PU-11174.0
9	1	Slide	ME-6607.6

ATTENTION:

If a belt needs to be replaced, all belts must be changed. There must never be a single belt replacement

Dasher draft support unit: MANTEGEL 70

TrasmissioneM70

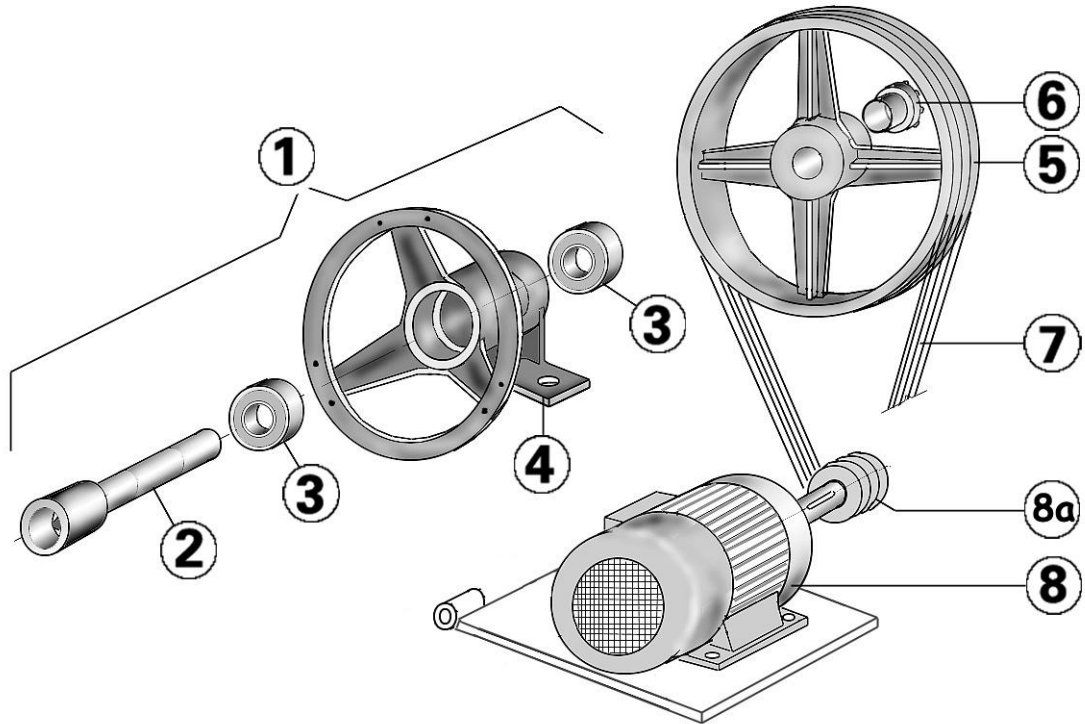

Pos.	N° Pieces	Name	Code
1	1	Complete support	ME-7138.4
2	1	Shaft support	ME-4949.2
3	3	Bearing support	CS-6610.6
4	1	Aluminium body support	ME-4379.0/02
5	1	Pulley support	M2-11699.0
6	1	Pulley wedge	PU-6599.6
7	5	Transmission belt A61	M2-0115
8*	1	Dasher motor	380V-420V/50Hz 440V-480V/60Hz 220V/50Hz 220V/60Hz 200V-50/60Hz
8a	1	Pulley motor	MO-11206.6 MO-11206.6 MO-11206.6/2 MO-15272.6 MO-11206.6/2B
			ME-11698.0/10

ATTENTION:

If a belt needs to be replaced, all belts must be changed. There must never be a single belt replacement

"Wash tap" unit (Only for MANTEGEL 30-50-70)

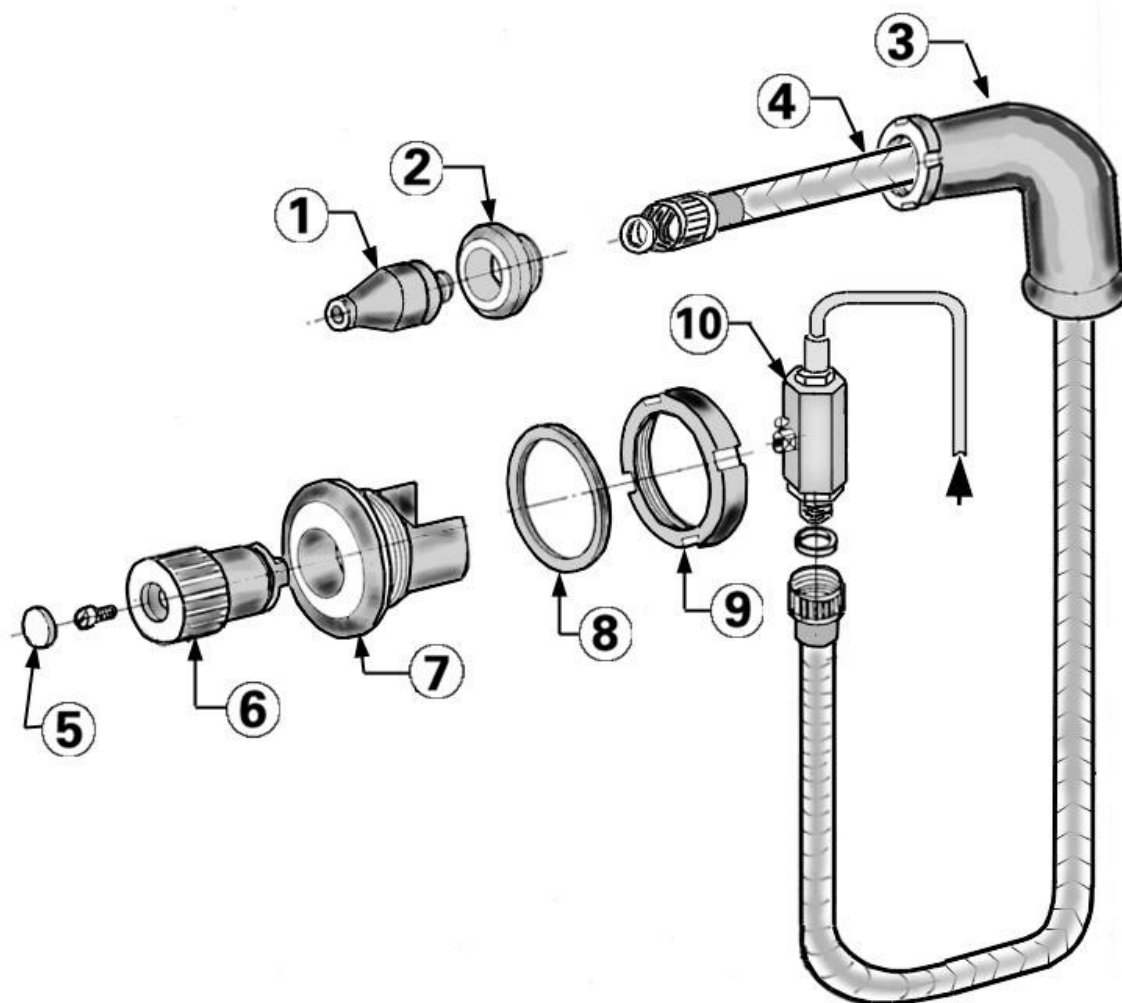

RubinettoLavaggio

Pos.	Name	Code
1	Mouth washing	ME-8963.0
2	Compass tube washing	PMT-6894.0/01
3	Metal ring with Tube Guides	ME-7377.2/20
4	Flexible for Shower 1/2" X 2 MT	ME-0084/1,5
5	Cover Lever Tap	ME-7370.0
6	Lever Tap	ME-8183.0
7	Complete Compass Tap	ME-7218.3/03
8	Washer Breech M50E	ME-2159.0
9	Metal ring Breech M50E	ME-2158.0
10	3/8" ball type faucet	RG-7696.6

"Bodywork" unit: MANTEGEL 20

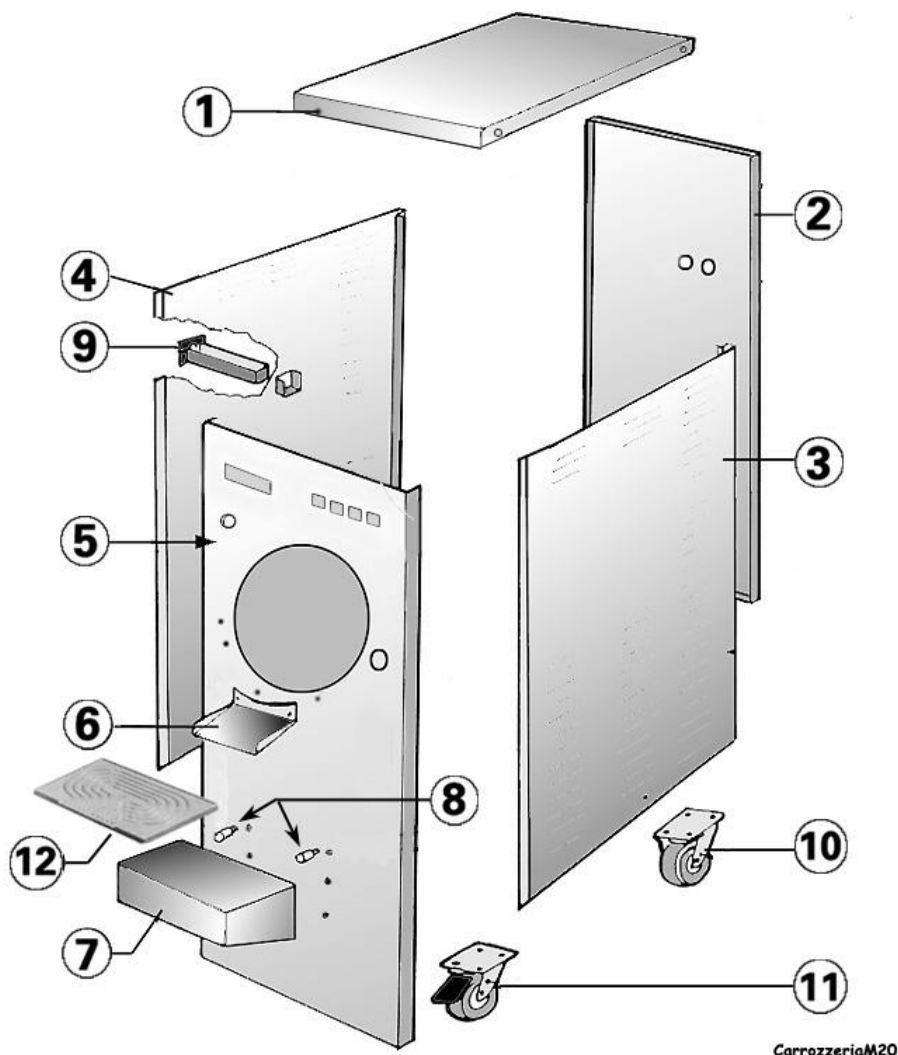

Pos.	Name	MANTEGEL 20 Code
1	Machine cover	M2-15632.0
2	Back panel	M2-15631.2/10
3	Right side panel	M2-15629.0/10
4	Left side panel	M2-15630.2/10
5	Printed front panel	M2-15628.2
6	Ice-cream exit slide	ME-21288.2
7	Ice-cream basin support	ME-8180.0/10
8	Screw support block (6 pieces)	ME-3345.0
9	Ice-cream leakage drawer	ME-0044
10	Fixed wheel (2 pieces)	PC-5165.6
11	Rotating wheel (2 pieces)	PC-5166.6
12	Tappeto	ME-21463.0

"Bodywork" unit: MANTEGEL 30 – 50 - 70

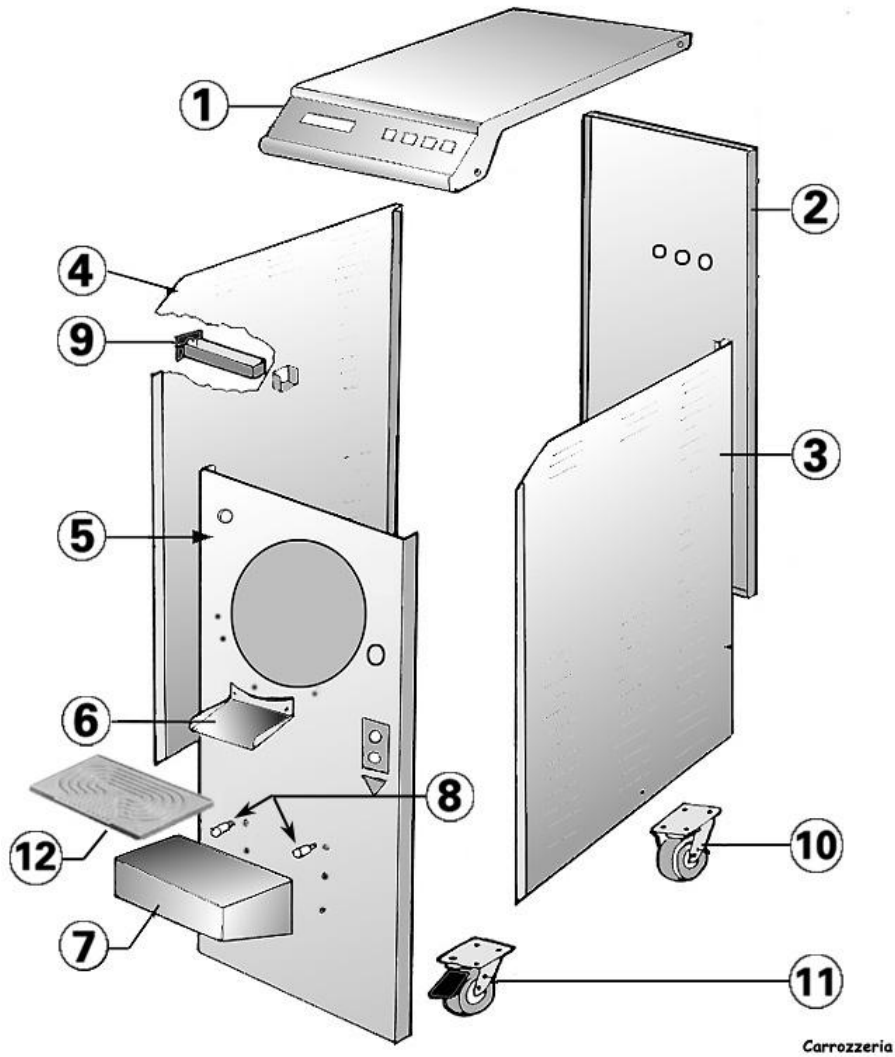

Pos.	Name	MANTEGEL 30 Code	MANTEGEL 50 Code	MANTEGEL 70 Code
1	Machine cover without rating plate	ME-8174.2/40	ME-8175.2/40	ME-8176.2/40
2	Back panel	ME-8203.2	ME-8418.2	ME-8419.0
3	Right side panel	ME-8415.0	ME-8417.0	ME-8420.2
4	Left side panel	ME-8416.2	ME-8195.3	ME-8196.3/10
5	Printed front panel	ME-8194.3	ME-8204.2	ME-8206.2
6	Ice-cream exit slide	ME-21288.2	ME-21288.2	ME-21288.2
7	Ice-cream basin support	ME-8180.0/10	ME-8180.0/10	ME-8180.0/10
8	Screw support block (6 pieces)	ME-3345.0	ME-3345.0	ME-3345.0
9	Ice-cream leakage drawer	ME-0044	ME-0044	ME-0044
10	Fixed wheel (2 pieces)	PC-5165.6	PC-5165.6	PC-8169.6
11	Rotating wheel (2 pieces)	PC-5166.6	PC-5166.6	PC-8170.6
12	Tappeto	ME-21463.0	ME-21463.0	ME-21463.0

Electric panel: MANTEGEL 20

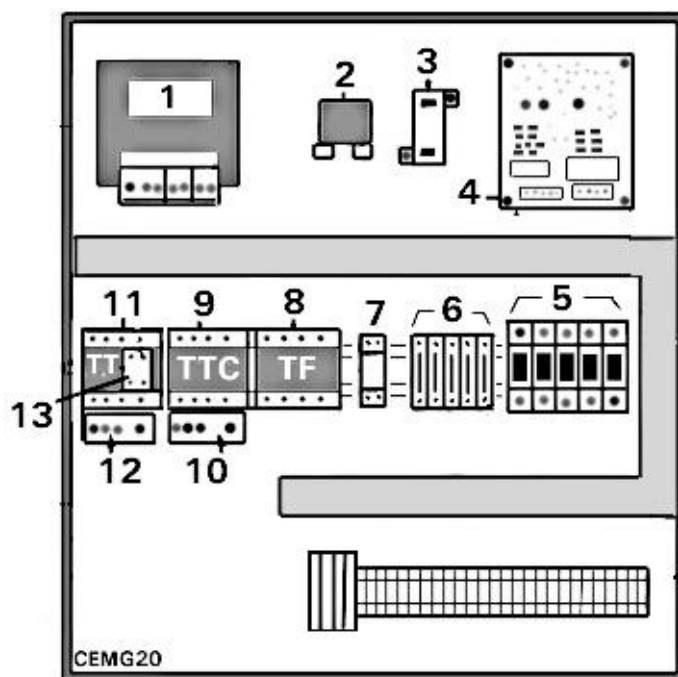

Pos.	N° pez	Nome componente	MANTEGEL 20 Codice
1	1	Trasformatore 240 VA - 220/380 24	FR1-032/S
2	1	Trasformatore elettronica	CC-13972.6
3	1	Trasformatore amperometrico TA	ME-0015
4	1	Scheda elettronica freno motore	CC-11594.6
5	3	Fusibili 10 x 38 16A tipo AM	E-00155/16AM
	2	Fusibili 10 x 38 4A tipo AM	E-00153/4AM
6	1	Fusibile in vetro 5 x 20 0,5A tipo rapido	ME-0053/0
	2	Fusibile in vetro 5 x 20 6,3A tipo ritardato	CC-9656.6
	2	Fusibile in vetro 5 x 20 6,3A tipo ritardato	CC-9656.6
7	1	Relay	CC-10375.6
8	1	Contattore freno tipo LC1 D12 10	FR3-0158
9	1	Contattore compressore frigo tipo LC1 D09 01	MX-0180
10	1	Salvamotore termico motore LR2D13 4-6A.	LN-0045
11	1	Contattore motore tipo LC1 D09 01	MX-0180
12	1	Salvamotore termico compressore LR2D13 4-6A.	LN-0045
13	1	Contatto ausiliario tipo LA1 DN11	FR3-0162

Electric panel: MANTEGEL 30 – 50 V.220/50 and 60hz

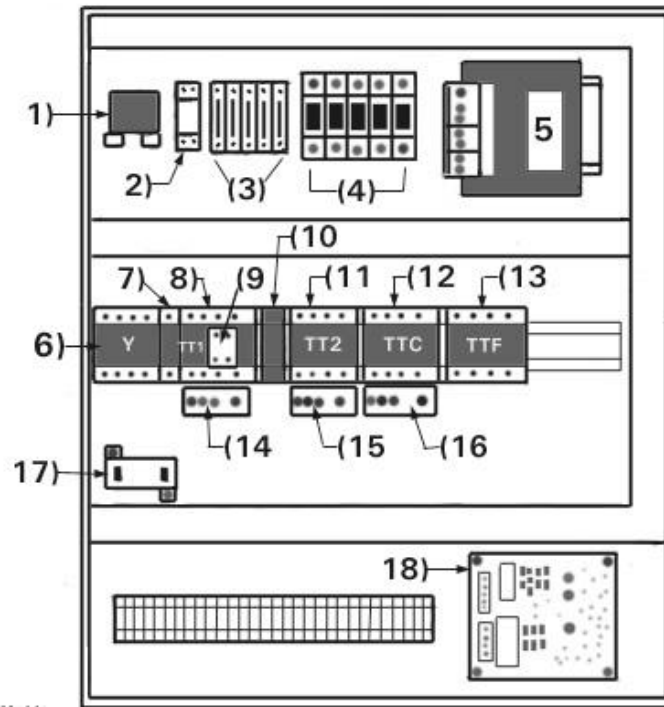

Mg44

Pos.	N° pez	Nome componente	MANTEGEL 30 Codice	MANTEGEL 50 Codice
1	1	Trasformatore elettronica	CC-13972.6	CC-13972.6
2	1	Relay	CC-10375.6	CC-10375.6
3	1	Fusibile in vetro 5 x 20 0,5A tipo rapido	ME-0053/0	ME-0053/0
	2	Fusibile in vetro 5 x 20 2A tipo rapido	ME-0053/2	ME-0053/2
	2	Fusibile in vetro 5 x 20 6,3A tipo ritardato	CC-9656.6	CC-9656.6
4	3	Fusibili 10 x 38 25A (MG30) 32A (MG50) tipo AM	E-00067/25AM	E-00067/32AM
	2	Fusibili 10 x 38 16A tipo AM	E-00067/16AM	E-00067/16AM
5	1	Trasformatore 160 VA - 220/380 24 - 200 24	FR1-032 FR1-032/2B	FR1-032 FR1-032/2B
6	1	Contattore chiusura stella tipo LC1 D09 D7	CC-16320.6	CC-16320.6
7	1	Intertblocco elettrico LAD 9R1V	CC-16325.6	CC-16325.6
8	1	Contattore motore I° velocità tipo LC1 D12 6B7	CC-16321.6	CC-16321.6
9	1	Contatto ausiliario tipo LAD N11	CC-16327.6	CC-16327.6
10	1	Intertblocco meccanico LAD 9R1	CC-16326.6	CC-16326.6
11	1	Contattore motore II° velocità tipo LC1 D12 6B7	CC-16321.6	CC-16321.6
12	1	Contattore compressore frigo tipo LC1 D12 6B7	CC-16321.6	CC-16321.6
13	1	Contattore freno tipo LC1 D18 6B7	CC-16322.6	CC-16322.6
14	1	Salvamotore termico I° velocità: - MANTEGEL 30 8-10A. LRD-14 - MANTEGEL 50 12-18A. LRD-21	CC-16330.6	CC-16332.6
15	1	Salvamotore termico II° velocità: - MANTEGEL 30 12-18A. LRD-21 - MANTEGEL 50 17-25A. LRD-22	CC-16332.6	CC-16333.6
16	1	Salvamotore termico compressore: - MANTEGEL 30 9-13A. LRD-16 - MANTEGEL 50 12-18A. LRD-21	CC-16331.6	CC-16332.6
17	1	Trasformatore amperometrico TA	ME-0015	ME-0015
18	1	Scheda elettronica freno motore	CC-11594.6	CC-11594.6

Electric panel: MANTEGEL 30 - 50 V.400

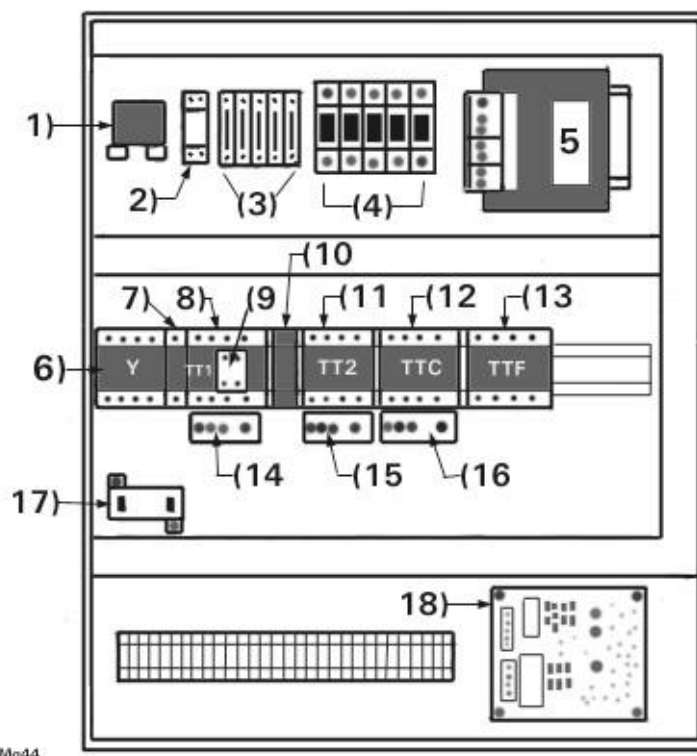

Mg44

Pos.	N° pez	Nome componente	MANTEGEL 30 Codice	MANTEGEL 50 Codice
1	1	Trasformatore elettronica	CC-13972.6	CC-13972.6
2	1	Relay	CC-10375.6	CC-10375.6
3	1	Fusibile in vetro 5 x 20 0,5A tipo rapido	ME-0053/0	ME-0053/0
	2	Fusibile in vetro 5 x 20 6,3A tipo ritardato	CC-9656.6	CC-9656.6
	2	Fusibile in vetro 5 x 20 6,3A tipo ritardato	CC-9656.6	CC-9656.6
4	3	Fusibili 10 x 38 20A (MG30) 25A (MG50) tipo AM	E-00067/20AM	E-00067/25AM
	2	Fusibili 10 x 38 6A tipo AM	E-00067/6AM	E-00067/6AM
5	1	Trasformatore 160 VA - 220/380 24 - 240/415 24	FR1-032 FR1-032/4	FR1-032 FR1-032/4
6	1	Contattore chiusura stella tipo LC1 D09 D7	CC-16320.6	CC-16320.6
7	1	Interblocco elettrico LAD 9R1V	CC-16325.6	CC-16325.6
8	1	Contattore motore I° velocità tipo LC1 D12 6B7	CC-16321.6	CC-16321.6
9	1	Contatto ausiliario tipo LAD N11	CC-16327.6	CC-16327.6
10	1	Interblocco meccanico LAD 9R1	CC-16326.6	CC-16326.6
11	1	Contattore motore II° velocità tipo LC1 D12 6B7	CC-16321.6	CC-16321.6
12	1	Contattore compressore frigo tipo LC1 D12 6B7	CC-16321.6	CC-16321.6
13	1	Contattore freno tipo LC1 D18 6B7	CC-16322.6	CC-16322.6
14	1	Salvamotore termico I° velocità: - MANTEGEL 30 4-6A. LRD-10 - MANTEGEL 50 8-10A. LRD-14	CC-16328.6	CC-16330.6
15	1	Salvamotore termico II° velocità: - MANTEGEL 30 8-10A. LRD-14 - MANTEGEL 50 12-18A. LRD-21	CC-16330.6	CC-16332.6
16	1	Salvamotore termico compressore: - MANTEGEL 30 4-6A. LRD-10 - MANTEGEL 50 5-8A LRD-12	CC-16328.6	CC-16329.6
17	1	Trasformatore amperometrico TA	ME-0015	ME-0015
18	1	Scheda elettronica freno motore	CC-11594.6	CC-11594.6

Electric panel: MANTEGEL 50 Air Water

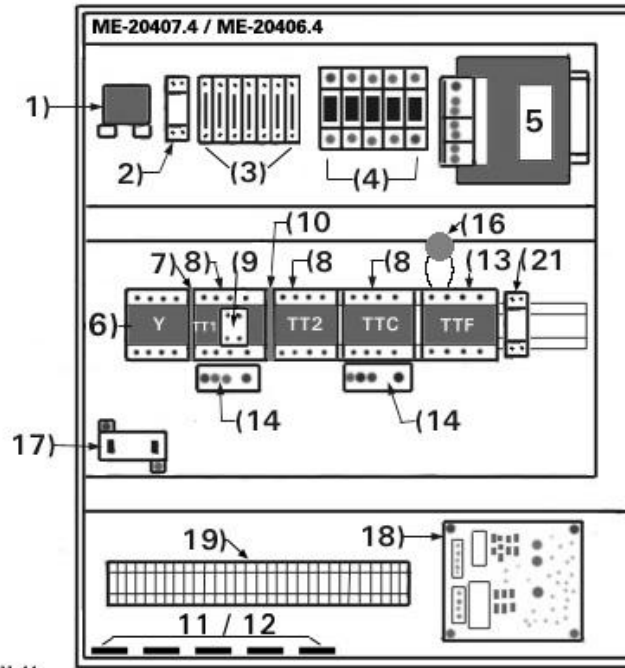

Mg44

ME-20406.4	Pos.	Q.tà	Descrizione Componente	Codice
	1	1	TRASF. 010VA V230-U12	CC-13972.6
	2	1	RELE' E25 S 24VAC X RESIST.	CC-10375.6
	2	1	ZOCOLO ZMEM/5 X RESISTENZA	CC-10376.6
	3	7	MORSETTI PORTAFUSIB. UK5-HESI	CC-16008.6
	3	2	FUSIBILE 5 AMP. VETRO 5 X 20	CC-16006.6
	3	1	FUSIBILE 0,5 A. VETRO 5 X 20	ME-0053/0
	3	4	FUSIBILE 6,3 RIT. VETRO 5X20	CC-9656.6
	4	1	PORTAFUSIBILE BIPOLARE 10X38	E-00153
	4	2	FUSIBILE 6 AMP. AM 10 X 38	E-00067/6AM
	5	1	TRASF. 240VA :100VA > U12/0/12	FR1-032/S
	6	1	TELER.TELEM. 9A LC1-D09B7	CC-16320.6
	7	1	INTERBLOCCO MECCAN. LAD-9R1V	CC-16325.6
	8	3	TELER.TELEM. 12A LC1-D12B7	CC-16321.6
	9	1	CONTATTO AUSILIARIO LAD-N11	CC-16327.6
	10	1	INTERBLOCCO MECC. LAD-9R1	CC-16326.6
	11	5	RACC. EL GHIERA PG21 PVC	E-00053
	11	5	RACC. EL PRESSACAVO PVC PG21	E-00114
	12	3	FUSIBILE 25 AMP. AM 10 X 38	E-00067/25AM
	12	1	PORTAFUSIBILE TRIPOL. 10 X 38	E-00155
	13	1	TELER.TELEM. 18A LC1-D18B7	CC-16322.6
	14	2	SALV.TELEM. 7,0-10,0 LRD-14	CC-16330.6
	16	1	VARISTORE D20 250V 130J	E-00487
	17	1	TRASFORMATORE AMP.100/01A	ME-0015
	18	1	SCHEDA FRENATURA PER MANTEGEL	CC-11594.6/10
	19	30	MORSETTI SCHLEGEL 4 MM	E-00380
	19	1	MORSETTI SCHLEGEL 4 MM BLU	E-00381
	19	1	MORSETTI SCHLEGEL 4 MM TERRA	E-00382
	19	1	SEPARATORE ISOL. SCHLEGEL IW4	E-00383
	19	2	STAFFA ARRESTO SCHLEGEL SK35	E-00384
	19	30	SEGNAMORS. SCHLEGEL (10 PEZZI)	E-00385
	20	1	PONTE DIODI 25A 1000V	LN-0051
	21	1	RELE FINDER 5532 10A 24V AC	T1-0209
	21	1	ZOCOLO OMRON OMPYFO8A-E	LN-0081

Electric panel: MANTEGEL 50 Air

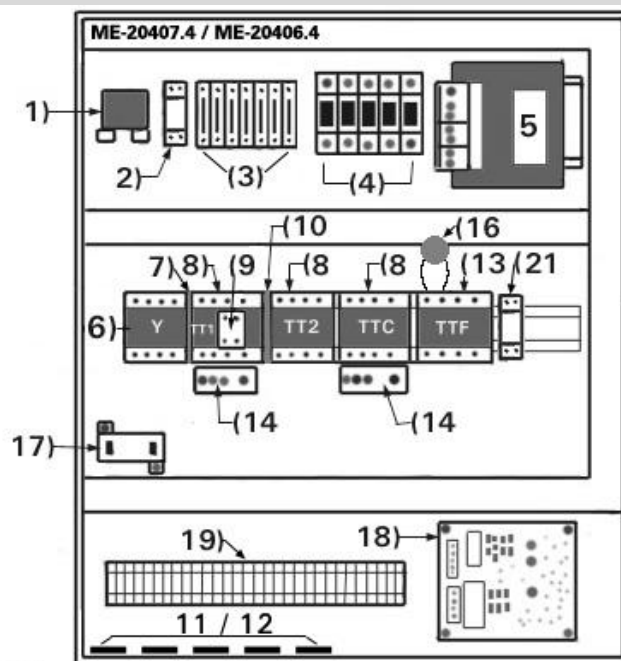

Mg44

ME-20407.4	Pos.	Q.tà	Descrizione Componente	Codice
	1	1	TRASF. 010VA V230-U12	CC-13972.6
	2	1	RELE' E25 S 24VAC X RESIST.	CC-10375.6
	2	1	ZOCOLO ZMEM/5 X RESISTENZA	CC-10376.6
	3	7	MORSETTI PORTAFUSIB. UK5-HESI	CC-16008.6
	3	2	FUSIBILE 5 AMP. VETRO 5 X 20	CC-16006.6
	3	1	FUSIBILE 0,5 A. VETRO 5 X 20	ME-0053/0
	3	4	FUSIBILE 6,3 RIT. VETRO 5X20	CC-9656.6
	4	1	PORTAFUSIBILE BIPOLARE 10X38	E-00153
	4	2	FUSIBILE 6 AMP. AM 10 X 38	E-00067/6AM
	5	1	TRASF. 240VA :100VA > U12/0/12	FR1-032/S
	6	1	TELER.TELEM. 9A LC1-D09B7	CC-16320.6
	7	1	INTERBLOCCO MECCAN. LAD-9R1V	CC-16325.6
	8	3	TELER.TELEM. 12A LC1-D12B7	CC-16321.6
	9	1	CONTATTO AUSILIARIO LAD-N11	CC-16327.6
	10	1	INTERBLOCCO MECC. LAD-9R1	CC-16326.6
	11	5	RACC. EL GHIERA PG21 PVC	E-00053
	11	5	RACC. EL PRESSACAPO PVC PG21	E-00114
	12	3	FUSIBILE 25 AMP. AM 10 X 38	E-00067/25AM
	12	1	PORTAFUSIBILE TRIPOL. 10 X 38	E-00155
	13	1	TELER.TELEM. 18A LC1-D18B7	CC-16322.6
	14	2	SALV.TELEM. 7,0-10,0 LRD-14	CC-16330.6
	16	1	VARISTORE D20 250V 130J	E-00487
	17	1	TRASFORMATORE AMP.100/01A	ME-0015
	18	1	SCHEDA FRENATURA PER MANTEGEL	CC-11594.6/10
	19	30	MORSETTI SCHLEGEL 4 MM	E-00380
	19	1	MORSETTI SCHLEGEL 4 MM BLU	E-00381
	19	1	MORSETTI SCHLEGEL 4 MM TERRA	E-00382
	19	1	SEPARATORE ISOL. SCHLEGEL IW4	E-00383
	19	2	STAFFA ARRESTO SCHLEGEL SK35	E-00384
	19	30	SEGNAMORS. SCHLEGEL (10 PEZZI)	E-00385
	20	1	PONTE DIODI 25A 1000V	LN-0051
	21	1	RELE FINDER 5532 10A 24V AC	T1-0209
	21	1	ZOCOLO OMRON OMPYF08A-E	LN-0081

Quadro elettrico: MANTEGEL 50 Inverter Aria Acqua

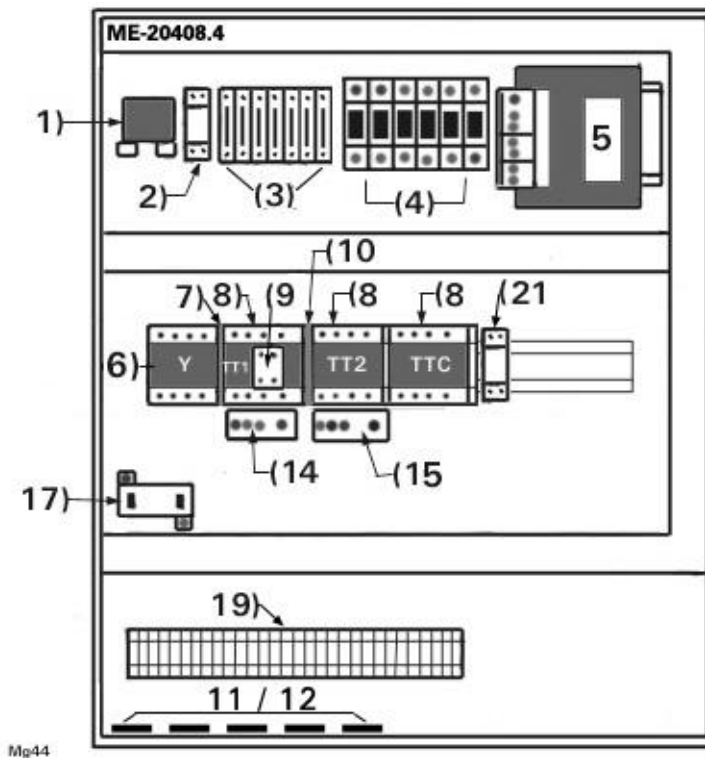

Mg44

ME-20408.4	Pos.	Q.tà	Descrizione Componente	Codice
	1	1	TRASF. 010VA V230-U12	CC-13972.6
	2	1	RELE' E25 S 24VAC X RESIST.	CC-10375.6
	2	1	ZOCOLO ZMEM/5 X RESISTENZA	CC-10376.6
	3	7	MORSETTI PORTAFUSIB. UK5-HESI	CC-16008.6
	3	2	FUSIBILE 5 AMP. VETRO 5 X 20	CC-16006.6
	3	1	FUSIBILE 0,5 A. VETRO 5 X 20	ME-0053/0
	3	4	FUSIBILE 6,3 RIT. VETRO 5X20	CC-9656.6
	4	3	FUSIBILE 25 AMP. AM 10 X 38	E-00067/25AM
	4	2	PORTAFUSIBILE TRIPOL. 10 X 38	E-00155
	4	3	FUSIBILE 10 AMP. AM 10 X 38	E-00067/10AM
	4	1	PORTAFUSIBILE BIPOLARE 10X38	E-00153
	5	1	TRASF. 240VA :100VA > U12/0/12	FR1-032/S
	6	1	TELER.TELEM. 9A LC1-D09B7	CC-16320.6
	7	1	INTERBLOCCO MECCAN. LAD-9R1V	CC-16325.6
	8	3	TELER.TELEM. 12A LC1-D12B7	CC-16321.6
	9	1	CONTATTO AUSILIARIO LAD-N11	CC-16327.6
	10	1	INTERBLOCCO MECC. LAD-9R1	CC-16326.6
	21	1	RELE FINDER 5532 10A 24V AC	T1-0209
	14	1	SALV.TELEM. 7,0-10,0 LRD-14	CC-16330.6
	15	1	SALV.TELEM. 12,0-18,0 LRD-21	CC-16332.6
	17	1	TRASFORMATORE AMP.100/01A	ME-0015
	19	30	MORSETTI SCHLEGEL 4 MM	E-00380
	19	1	MORSETTI SCHLEGEL 4 MM BLU	E-00381
	19	1	MORSETTI SCHLEGEL 4 MM TERRA	E-00382
	19	1	SEPARATORE ISOL. SCHLEGEL IW4	E-00383
	19	2	STAFFA ARRESTO SCHLEGEL SK35	E-00384
	19	30	SEGNAMORS. SCHLEGEL (10 PEZZI)	E-00385

Electric panel: MANTEGEL 70 V.400

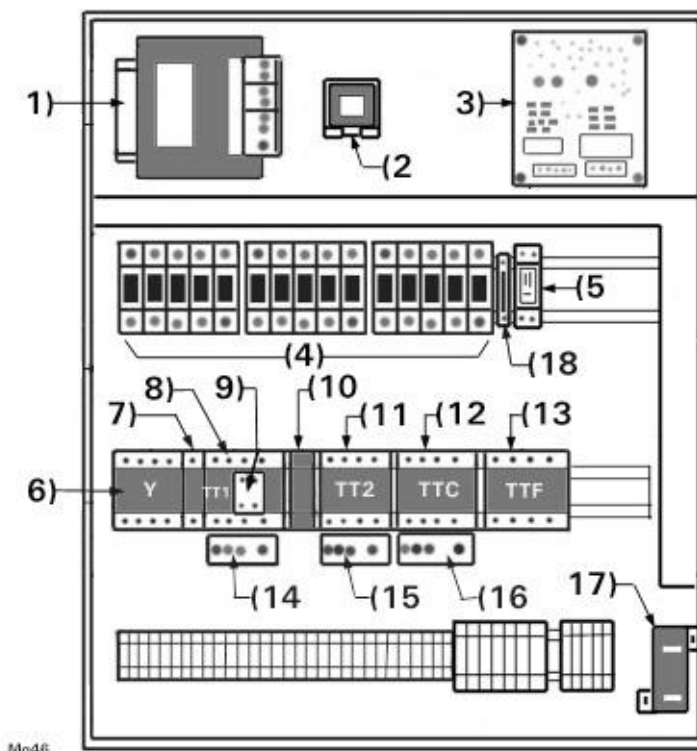

Mg46

Pos.	N° Pez	Nome componente	Codice
1	1	Trasformatore 500 VA - 220/380 24 - 240/415 24	FR6-0246 FR6-0246/4
2	1	Trasformatore elettronica	CC-13972.6
3	1	Scheda elettronica freno motore	CC-11594.6
4	9	Fusibili 10 x 38 16A. tipo AM	E-00067/16AM
	2	Fusibili 10 x 38 8A. tipo AM	E-00067/8AM
	2	Fusibili 10 x 38 10A. tipo rapido	E-00067/10GL
	2	Fusibili 10 x 38 8A. tipo AM	E-00067/8AM
5	1	Relay	CC-10375.6
6	1	Contattore chiusura stella tipo LC1 D18 6B7	CC-16322.6
7	1	Interblocco elettrico LA9 9R1V	CC-16325.6
8	1	Contattore motore I° velocità tipo LC1 D18 6B7	CC-16322.6
9	1	Contatto ausiliario tipo LAD N11	CC-16327.6
10	1	Interblocco meccanico LAD 9R1	CC-16326.6
11	1	Contattore motore II° velocità tipo LC1 D18 6B7	CC-16322.6
12	1	Contattore compressore frigo tipo LC1 D18 6B7	CC-16322.6
13	1	Contattore freno tipo LC1 D18 6B7	CC-16322.6
14	1	Salvatore termico I° velocità: 12-18A. LRD-21	CC-16332.6
15	1	Salvatore termico II° velocità: 12-18A. LRD-21	CC-16332.6
16	1	Salvatore termico compressore: 9-13A. LRD-16	CC-16331.6
17	1	Trasformatore amperometrico TA	ME-0015
18	1	Fusibile in vetro 5 x 20 0,5A. tipo rapido	ME-0053/0

Electric panel: MANTEGEL 70 V.220 50 and 60Hz

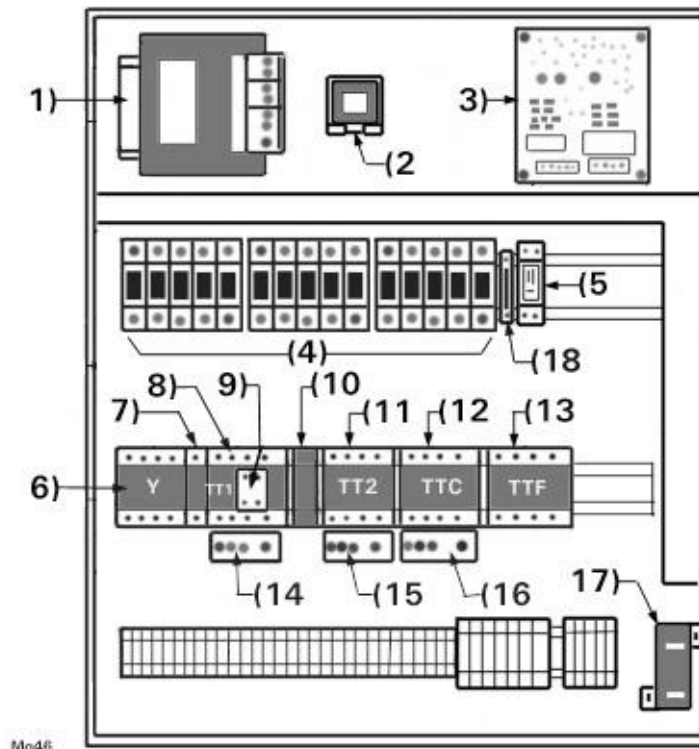

Mg46

Pos.	N° Pez	Nome componente	Codice
1	1	Trasformatore 300 VA - 220/380 24 - 200 24	FR6-0115 FR6-0115/2B
2	1	Trasformatore elettronica	CC-13972.6
3	1	Scheda elettronica freno motore	CC-11594.6
4	9	Fusibili 10 x 38 25A. tipo AM	E-00067/25AM
	2	Fusibili 10 x 38 8A. tipo AM	E-00067/8AM
	2	Fusibili 10 x 38 10A. tipo rapido	E-00067/10GL
	2	Fusibili 10 x 38 16A. tipo AM	E-00067/16AM
5	1	Relay	CC-10375.6
6	1	Contattore chiusura stella tipo LC1 D25 6B7	CC-16324.6
7	1	Interblocco elettrico LA9 9R1V	CC-16325.6
8	1	Contattore motore I° velocità tipo LC1 D25 6B7	CC-16324.6
9	1	Contatto ausiliario tipo LAD N11	CC-16327.6
10	1	Interblocco meccanico LAD 9R1	CC-16326.6
11	1	Contattore motore II° velocità tipo LC1 D25 6B7	CC-16324.6
12	1	Contattore compressore frigo tipo LC1 D25 6B7	CC-16324.6
13	1	Contattore freno tipo LC1 D32 6B7	CC-16323.6
14	1	Salvamotore termico I° velocità: 17-25A. LRD-22	CC-16333.6
15	1	Salvamotore termico II° velocità: 23-32A. LRD-32	CC-16334.6
16	1	Salvamotore termico compressore: 17-25A. LRD-22	CC-16333.6
17	1	Trasformatore amperometrico TA	ME-0015
18	1	Fusibile in vetro 5 x 20 0,5A. tipo rapido	ME-0053/0

Gruppo “ Dispositivo Granita ”

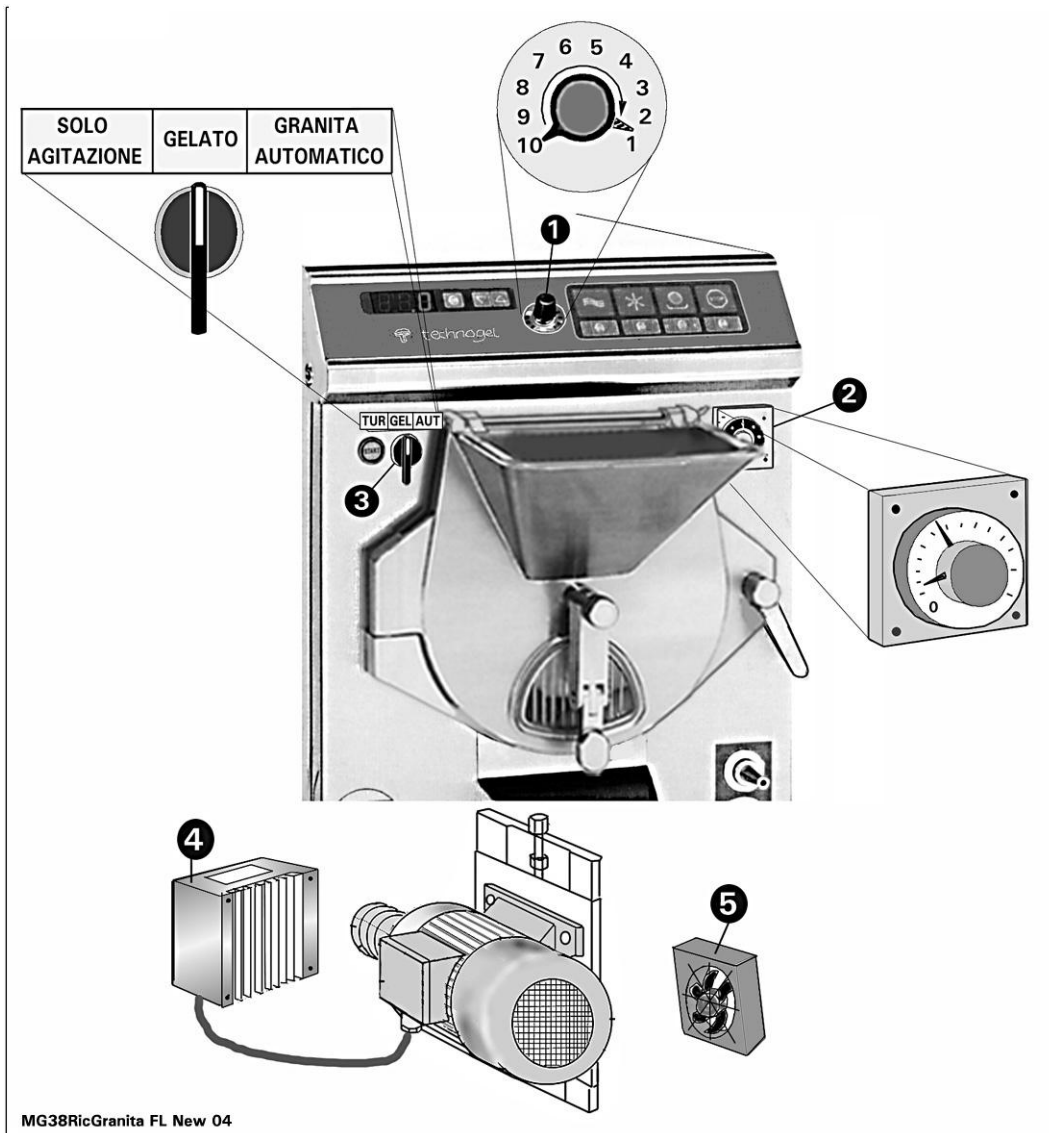

MG38RicGranita FL New 04

Pos.	Componente	MANTEGEL 20 Codice	MANTEGEL 30 Codice	MANTEGEL 50 Codice
1	Potenziometro regolazione velocità	CC-8586.6	CC-8586.6	CC-8586.6
2	Temporizzatore pausa-lavoro	CC-10038.6	CC-10038.6	CC-10038.6
3	Commutatore	FR6-0270	FR6-0270	FR6-0270
4	Inverter ATV-28HU29N4	CC-17855.6		
	Inverter ATV-28HU41N4		CC-17010.6	
	Inverter ATV-28HU72N4			CC-18015.6
5	Ventilatore raffreddamento motore	DFA-5048.6	DFA-5048.6	DFA-5048.6

Kit Gasket Flange Unit

Macchina	Periodo di Fabbricazione	Codice
Mantegel 20E	<i>dal 1987 al 1991</i>	M2-0118/10
Mantegel 30E	<i>dal 1987 al 1991</i>	M2-0118/10
Mantegel 50E	<i>dal 1987 al 1991</i>	ME-0079/10
Mantegel 70E	<i>dal 1987 al 1991</i>	ME-0319/10

Macchina	Periodo di Fabbricazione	Codice
Mantegel 20E	<i>dal 1992 al 06 / 2003</i>	M2-0179/10
Mantegel 30E	<i>1992</i>	ME-0276/10
Mantegel 50E	<i>1992</i>	ME1-0128/10
Mantegel 70E	<i>1992</i>	ME-0351/10

Macchina	Periodo di Fabbricazione	Codice
Mantegel 30E	<i>dal 1993 al 06 / 2003</i>	ME-0277/10
Mantegel 50E	<i>dal 1993 al 06 / 2003</i>	ME1-0129/10
Mantegel 70E	<i>dal 1993 al 06 / 2003</i>	ME-0352/10

Macchina	Periodo di Fabbricazione	Codice
Mantegel 20E	<i>dal 07 / 2003</i>	ME-21027.4
Mantegel 30E	<i>dal 07 / 2003</i>	ME-21027.4
Mantegel 50E	<i>dal 07 / 2003</i>	ME-21028.4
Mantegel 70E	<i>dal 07 / 2003</i>	ME-21029.4

Machine positioning with air cooling

It is most important to position the machine in a roomy environment with doors and windows to facilitate ventilation of the heated air.

The rear of the machine must be at least 0.5 metres from the wall.

During machine operation the doors and windows of the room must be kept open otherwise the air heated by the machine will become extremely hot reaching a temperature as high as 50°C. If the machine operates in heated condition for long periods the machine's main components (refrigerator compressor and turbine motor) will overheat to such an extent that the machine's operation will be adversely affected. This will lead to bad performance and thus unnecessary expense and cost. In addition excessive heat will increase electricity consumption and yield may fall to below 50%.

IDEAL POSITIONING OF THE MACHINE

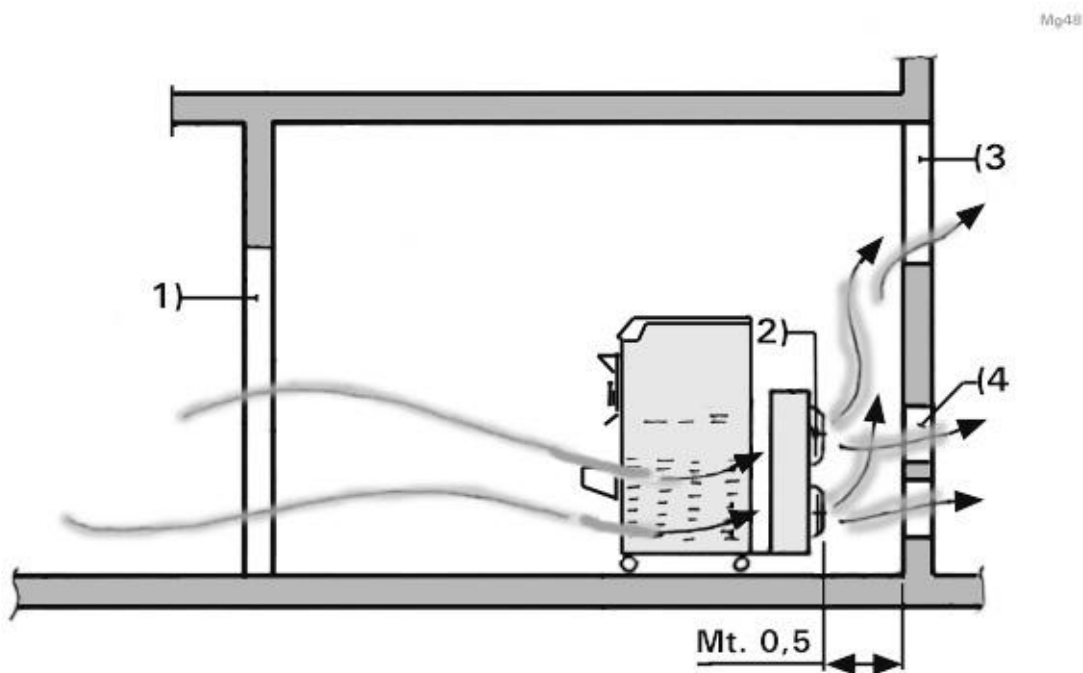

As can be seen in the diagram, the air entering through door (1) is sucked in and heated during condensation from the ventilators (2). It is then pushed towards the window (3) from which it exits.

Though not always practical, the ideal solution is to make holes in the wall (4), corresponding to the ventilators (2). This will let the air exit freely without impediments thus ensuring a consistently optimum yield from the machine.

TECHNOGEL spa CANNOT ASSUME ANY RESPONSIBILITY FOR DAMAGE CAUSED BY POSITIONING THE MACHINE IN UNSUITABLE ENVIRONMENTS. IN ADDITION TECHNOGEL IS NOT RESPONSIBLE FOR FALLS IN MACHINE YIELD CAUSED BY OPERATING UNDER LIMITING CONDITIONS.

Dimension machine air cooling

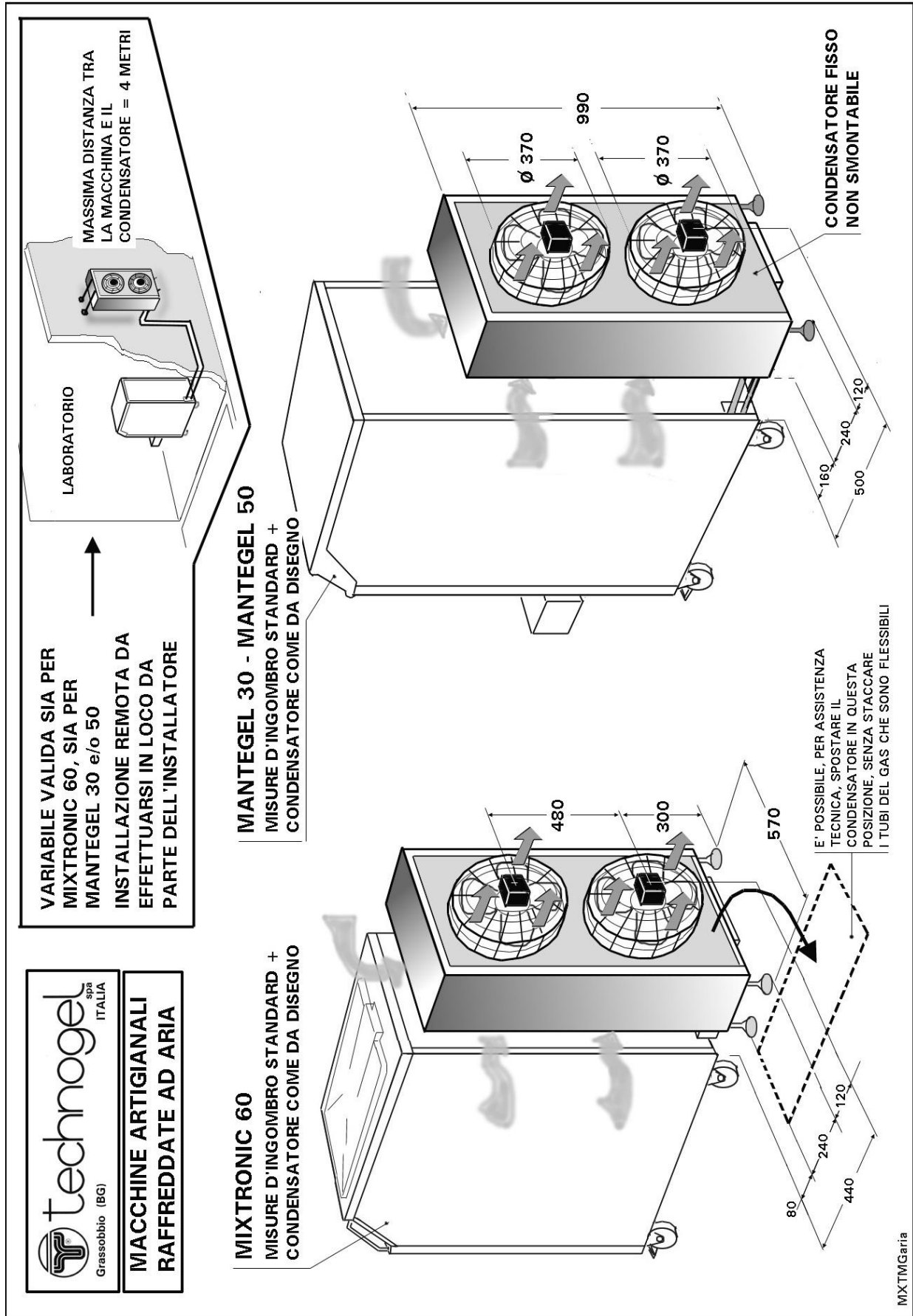

technogel
 Grassobbio (BG) spa
 ITALIA

**MACCHINE ARTIGIANALI
 RAFFREDDATE AD ARIA**

INDEX

Introduction	Pag 3
Person qualified to carry out the work depending on the type of work involved.	Pag 3
Installation and first start up.	Pag 3
How to unpack the machine.	Pag 4
Hoisting the machine.	Pag 5
Machine identification.	Pag 6
Positioning machine condenser for water.	Pag 7
Dimensions and different facilities: MANTEGEL 20 / 30 / 50 / 70	Pag 8
Electrics installation	Pag 12
Water connection	Pag 13
Machine positioning condenser for AIR o AIR WATER.	Pag 15
Cooling machine fixed. – Electric installations.	Pag 18
Machine start-up/rotation direction	Pag 20
Acceptable and unacceptable usage	Pag 21
Safety warning	Pag 23
Functions of the machine with preliminary checking an control.	Pag 25
Console control functions gel “ <i>BATCH FREEZING</i> ”	Pag 26
Console control functions “ <i>CONTROL KEYBOARD</i> ”	Pag 27
Start up. – Checking Efficient operation.	Pag 28
Checking the direction of rotation	Pag 29
Initial start up with the ice cream manufacturing.	Pag 31
Verify the batch freezer mixer turbine	Pag 32
Machine operation.	Pag 33
Operation of machine with Granita device.	Pag 35
Washing the machine.	Pag 39
Dismantling the batch freezer turbine mixer	Pag 41
Cleaning the lid and control console. – Never perform the following actions during washing	Pag 42
Maintenance.	Pag 43
Technical Characteristics with diagrams.	Pag 53
Mantegel 20 “ WATER”	Pag 54
Refrigerator plant Mantegel 20 Cooling “ WATER“	Pag 55
Mantegel 20 “ AIR”	Pag 56
Refrigerator plant Mantegel 20 Cooling “ AIR“	Pag 57
Mantegel 30 “ WATER”	Pag 58
Refrigerator plant Mantegel 30 Cooling “ WATER“	Pag 59
Mantegel 30 “ AIR”	Pag 60
Refrigerator plant Mantegel 30 Cooling “ AIR“	Pag 61
Mantegel 30 “ AIR WATER”	Pag 62
Refrigerator plant Mantegel 30 Cooling “ AIR WATER“	Pag 63
Mantegel 50 “ WATER”	Pag 64
Refrigerator plant Mantegel 50 Cooling “ WATER“	Pag 65
Mantegel 50 “ AIR”	Pag 66
Refrigerator plant Mantegel 50 Cooling “ AIR“	Pag 67
Mantegel 50 “ AIR WATER”	Pag 68
Refrigerator plant Mantegel 50 Cooling “ AIR WATER“	Pag 69
Mantegel 70 “ WATER”	Pag 70
Refrigerator plant Mantegel 70 Cooling “ WATER“	Pag 71
Electrical plant.	Pag 73
Spare parts. – Technical Assistance.	Pag 87
Kit Gasket Front door Unit	Pag 108